



MXT-10241-GG25-St.St

Technical Features

CAST IRON WITH STAINLESS STEEL TRIM

- Design** : DIN 86251 STOP Type (DIN 3356)
- Face to Face** : EN 558 Series 1 (DIN 3202 F1)
- Flange Dimension** : DIN Flanges acc. to EN 1092-2/B (DIN 2501)
- Pressure Rating** : PN 4 - PN 16 (as mentioned in DIN 86251)
- Temperature Range** : -10 °C + 180 °C (as mentioned in DIN 86251)
- Options** : Regulating disc, drain plug
- Flange Options** : Special flange drilling acc. to ANSI or JIS

**GLOBE VALVE - STRAIGHT - BOLTED BONNET
DIN LENGTH - STOP TYPE**



PRESSURE AND TEMPERATURE RANGE

Bore	Permissible working pressure in bar		Hydraulic test pressure in bar for leak - tightness of	
	Working temperature		Casing (Cast)	Closure
	Up to 120 °C	Up to 120 °C - 180 °C		
DN 15 - DN 125	16	10	24	16
DN 150 - DN 200	10	6	15	10
DN 250 - DN 300	6	4	9	6
DN 350 - DN 600	4	2	6	4

MATERIAL SPECIFICATIONS

INTERNAL COMPONENTS	St. Steel (X20CR13)	St. Steel (AISI 304)	St. Steel (AISI 316)	COMPLETE AISI 316
Body, bonnet	EN-GJL250 (GG25)	EN-GJL250 (GG25)	EN-GJL250 (GG25)	EN-GJL250 (GG25)
Seats	AISI 304 (1.4301)	AISI 304 (1.4301)	AISI 316 (1.4401)	AISI 316 (1.4401)
Disc (<65)	X20Cr13 (1.4021)	AISI 304 (1.4301)	AISI 316 (1.4401)	AISI 316 (1.4401)
Disc (>80)	EN-GJS400-18-LT (GGG40.3)	EN-GJS400-18-LT (GGG40.3)	EN-GJS400-18-LT (GGG40.3)	AISI 316 (1.4401)
Stem	X20Cr13 (1.4021)	AISI 304 (1.4301)	AISI 316 (1.4401)	AISI 316 (1.4401)
Stud bolts, nuts	Steel	Steel	Steel	Steel
Bonnet gasket, gland packing	Graphite	Graphite	Graphite	Graphite
Hand wheel	EN-GJL250 (GG25)	EN-GJL250 (GG25)	EN-GJL250 (GG25)	EN-GJL250 (GG25)

DIMENSIONS

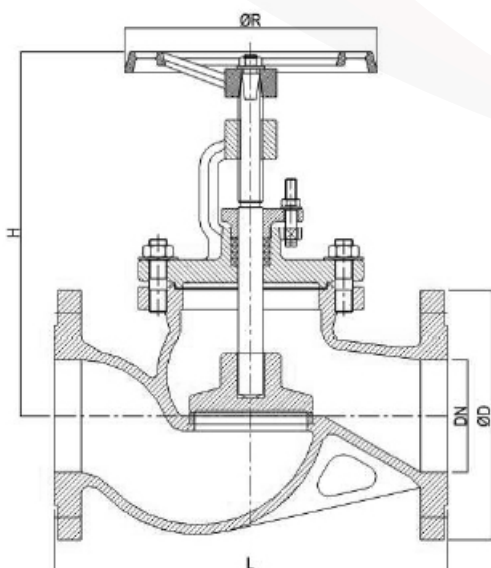

DN (mm)	ØD		L (mm)	H (mm)	ØR (mm)	Weight (kg)
	PN 10	PN 16				
15	95	95	130	165	120	3.8
20	105	105	150	165	120	4.0
25	115	115	160	180	140	5.0
32	140	140	180	180	140	7.0
40	150	150	200	215	160	11
50	165	165	230	230	160	13
65	185	185	290	245	180	18
80	200	200	310	295	200	23
100	220	220	350	325	225	35
125	250	250	400	360	250	53
150	285	285	480	425	300	75
175	315	315	550	495	400	115
200	340	340	600	505	400	135
250	395	405	730	625	520	215
300	445	460	850	690	520	305
350	505	520	980	755	640	405
400	565	580	1100	840	640	550
450	615	640	1200	920	640	750
500	670	715	1250	980	640	950
600	780	840	1450	1200	640	1250