

SKT9 type STAINLESS STEEL SIGHT GLASS

CHARACTERISTICS

The SKT9 sight glass is dedicated to the direct visual control of fluid flow in the pipes. Its stainless steel construction makes it suitable for applications in chemical process fluid flows and its double-window construction with a moving flapper improving the visual control of the flow. This sight glass complies with the EC and ATEX standards.

AVAILABLE ITEMS

DN 1/2" to 2"

3881223800: NPT threaded connections

3881224000: BSP threaded connections



LIMITS OF USE

Max. allowable pressure (PS)	16 bar
Min./max. allowable temperature (TS)	-20 °C / +180 °C
Room temperature	-20 °C / +60 °C

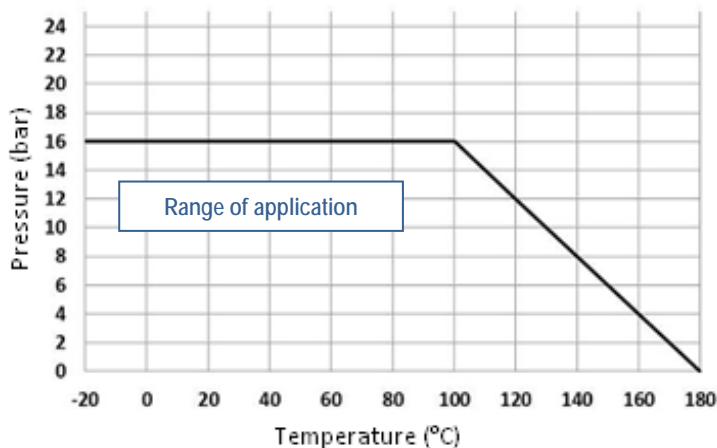

DIRECTIVES AND DEVELOPMENT STANDARDS APPLICABLE

	Standard	Notified bodies		Standard
97/23/EC Pressure Equipment Directive	1/4" to 1" : excluded		Shell design	EN 12516-1
	1"1/4 to 2" : category II	TÜV #0035	Material certificate	EN 10204 § 3.1
Alloy grade	EN 1503-1			
ATEX Directive	EN 13463-1	SIRA #0518	Room temperature -20 °C / +60 °C	Category II 2 G D TX

CONSTRUCTION

#	Item	Quantity	Material
1	Body	1	Stainless steel A351 CF8M / 1.4408
2	Caps	2	Stainless steel A351 CF8M / 1.4408
3	Glass	2	Tempered glass
4	Flat gasket	2	PTFE
5	Flat gasket	2	PTFE
6	Flapper	1	Stainless steel A351 CF8M / 1.4408
7	Stem	1	Stainless steel AISI 304

DN 1/2" to 1"

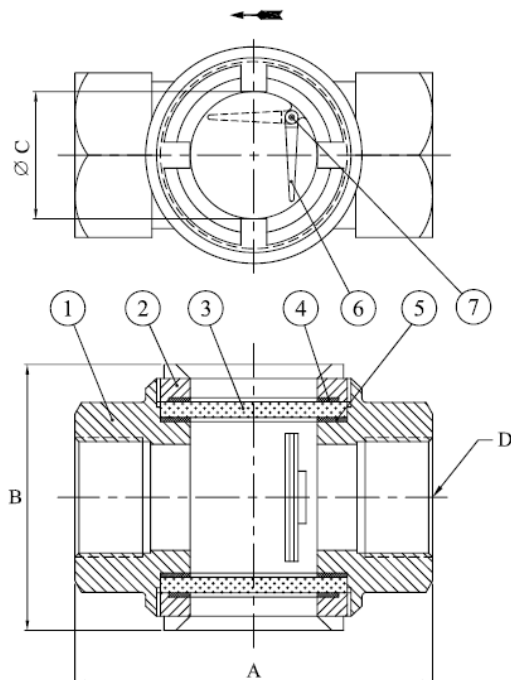

DN 1"1/4 to 2"

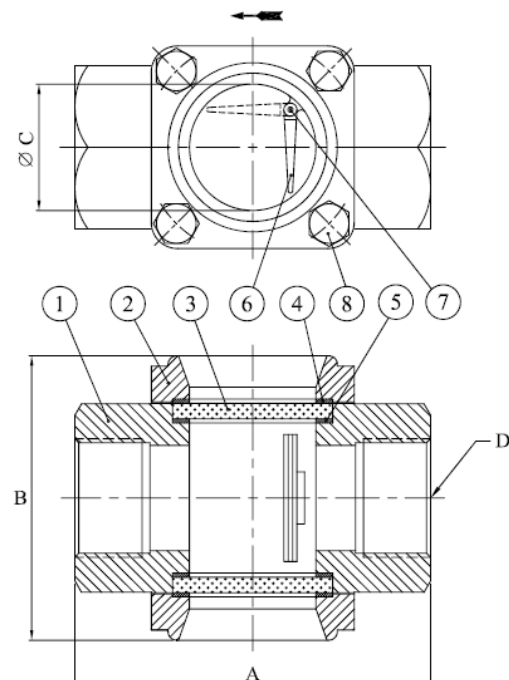

DIMENSIONS (mm) AND WEIGHT (kg)

DN	1/2"	3/4"	1"	1"1/4	1"1/2	2"
A	105	105	110	125	125	170
B	76	76	76	104	106	120
C	38	38	38	48	48	58
D (2238)	1/2" NPT	3/4" NPT	1" NPT	1"1/4 NPT	1"1/2 NPT	2" NPT
D (2240)	BSP 1/2"	BSP 3/4"	BSP 1"	BSP 1"1/4	BSP 1"1/2	BSP 2"
Weight	1	1	1.2	2.5	2.5	4.1

MOUNTING AND MAINTENANCE

- The sight glass can be installed in any position. In vertical position with flow down, the flapper will not function.
- Downstream from the steam trap, please keep a 1 metre distance between the steam trap and the sight glass in order to prevent from thermal shock on the glass.
- Please shut off the up and downstream pipes before installation.
- Depressurize and drain the piping.
- Please wait for its cooling to room temperature.
- Wear the necessary safety equipment for this type of intervention (gloves and glasses).
- Remove the cover and glass.
- Clean the internal parts.
- Check the glass condition in order to detect any possible corrosion or erosion mechanism and replace it if necessary.
- Screw the sight glass on the piping using an adapted gasket.
- Position the device so that glasses can be easily checked by operators.
- Put the device back to operation.

ATEX ZONE USE

The SKT9 sight glass complies with the EC-ATEX Directive and is certified for use in explosive zones. It can be installed in zones 1, 2, 21 and 22.

SPARE PARTS

It is a kit including 1 glass (*mark 3 on the drawing page 2*) and 2 gaskets (*mark 4 and 5*).

DN	Ø glass (mm)	Thickness (mm)	Reference
1/2" - 1"	55	10	981074A
1"1/4 - 1"1/2	60	10	981075A
2"	70	10	981076A

