

CARBON STEEL METAL EXPANSION JOINT WITH STAINLESS STEEL BELLOW BW

Carbon steel metal expansion joint with stainless steel bellow BW for high temperature networks.

Axial movement only.

With internal liner.



Size : DN25 to DN250

Connection : Butt Welding

Min Temperature : -20°C

Max Temperature : +300°C

Max Pressure : 16 Bars

Specifications : Axial movement

Stainless steel bellow

With internal liner

Materials : Carbon steel ends

CARBON STEEL METAL EXPANSION JOINT WITH STAINLESS STEEL BELLOW BW

SPECIFICATIONS :

- Axial movement
- Respect the flow direction indicated by the arrow
- Stainless steel bellow
- With internal liner
- Butt welding ends

USE :

- For common fluids of 2nd group
- Min Temperature Ts : - 20°C
- Max Temperature Ts :+ 300°C
- Max Pressure Ps : 16 bars (see graph)
- Axial movement only

PRESSURE / TEMPERATURE GRAPH (STEAM EXCLUDED) :

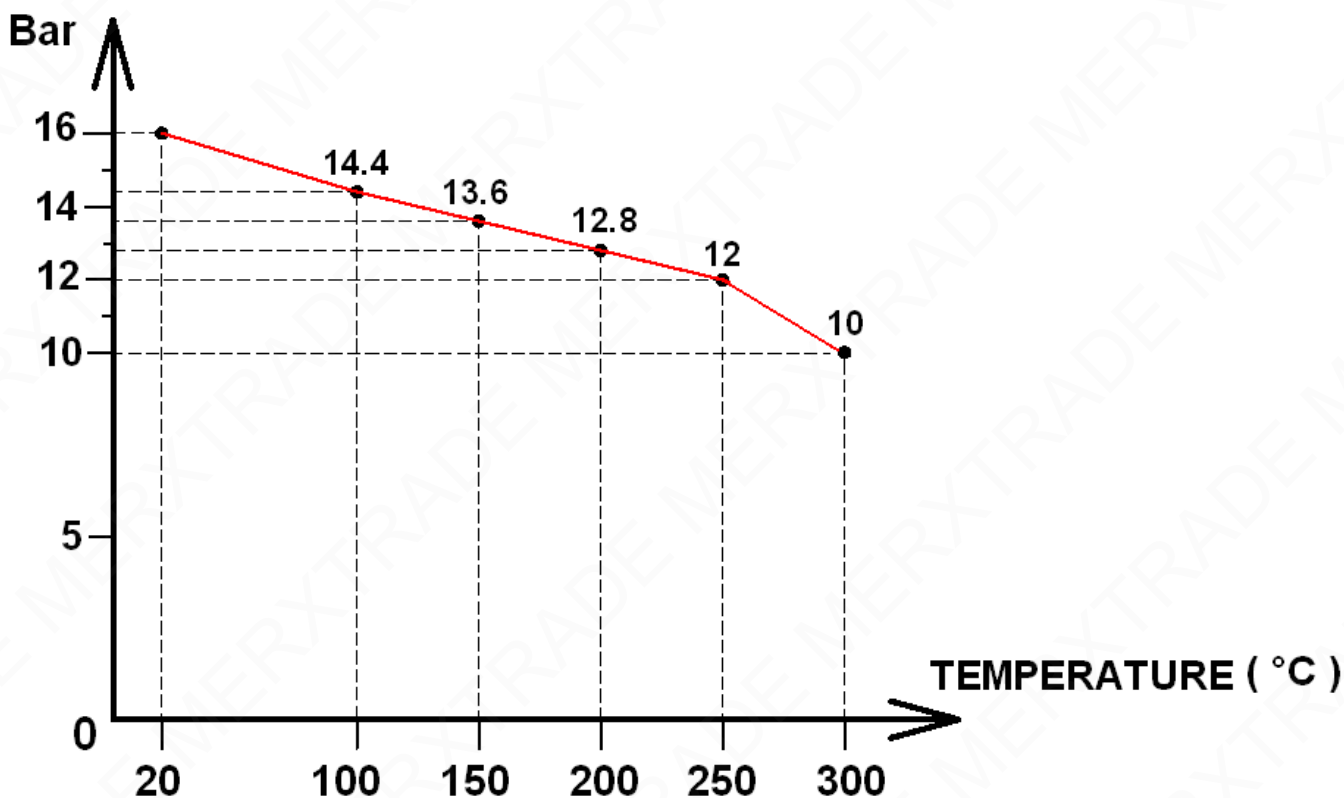

MOVEMENTS (in mm) :

DN	25	32	40	50	65	80	100	125	150	200	250
Axial Movement	± 11	± 10	± 13	± 20	± 20	± 25	± 32	± 33	± 40	± 33	± 40

CARBON STEEL METAL EXPANSION JOINT WITH STAINLESS STEEL BELLOW BW

RANGE :

- Carbon steel Butt Welding ends from DN25 to DN250

MATERIALS :

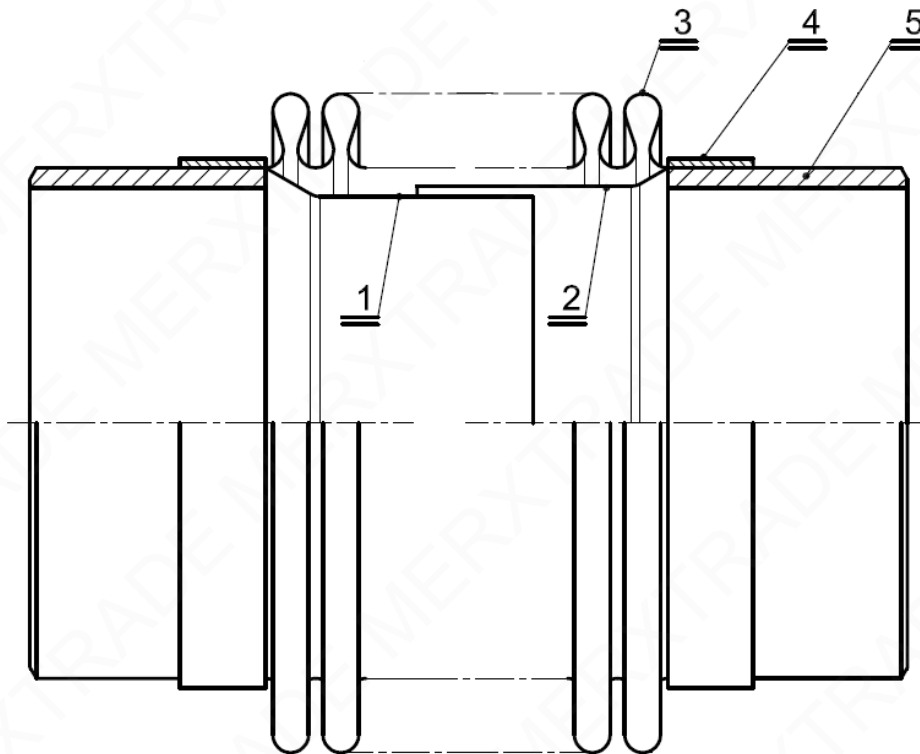

Item	Designation	Materials
1	Internal liner	AISI 321
2	Internal liner	
3	Bellow	
4	Band	
5	Ends	Steel St 37.2

CARBON STEEL METAL EXPANSION JOINT WITH STAINLESS STEEL BELLOW BW

SIZE (in mm) :

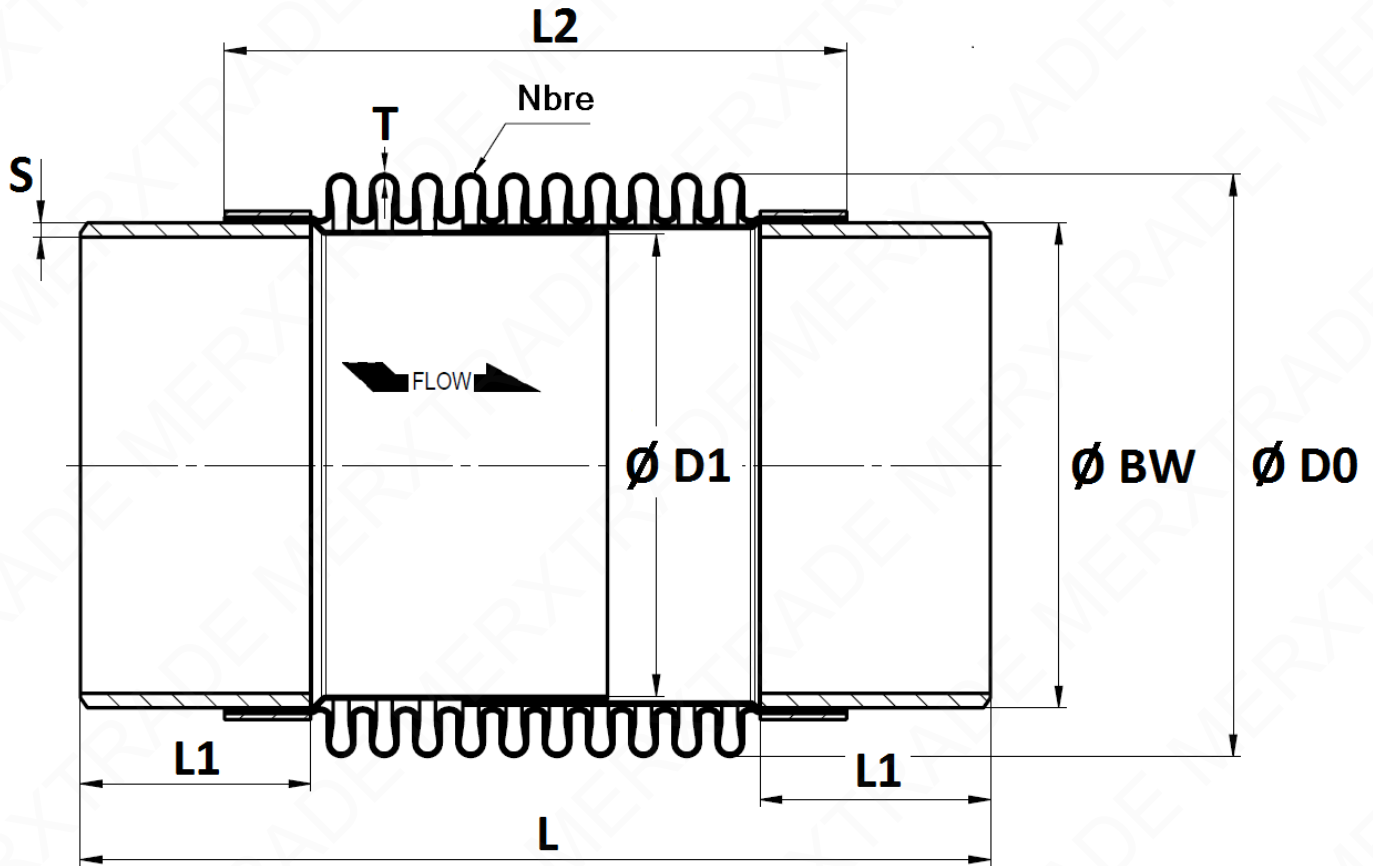

DN	25	32	40	50	65	80	100	125	150	200	250
L	185	185	200	270	260	275	310	310	350	330	360
L1	55	55	50	75	80	75	60	85	60	65	60
L2	105	105	120	140	120	145	210	160	250	220	260
Ø BW	38	42.4	48.3	60.3	76.1	88.9	114.3	139.7	168.3	219.1	273
Ø D0	48.8	55.6	61	77	96	112	141	165	201	252	325.8
Ø D1	32	36	41.4	53.5	70	78	103.5	127.3	156	207	261
S	2.6	2.6	2.6	2.9	2.9	3.2	3.6	4	4.5	6.3	6.3
T	0.3	0.3	0.3	0.4	0.4	0.5	0.6	0.6	0.6	0.8	1
Waves Nbre	17	17	17	20	16	15	20	16	20	16	14
Weight (in Kg)	0.37	0.44	0.53	1.11	1.37	1.86	2.94	3.89	5.85	9.4	13.97
Ref.	1511025	1511032	1511040	1511050	1511065	1511080	1511100	1511125	1511150	1511200	1511250

CARBON STEEL METAL EXPANSION JOINT WITH STAINLESS STEEL BELLOW BW

STANDARDS :

- Manufacturer certified ISO 9001 : 2015
- DIRECTIVE 2014/68/EU : CE N° 0408
Risk category II Module A2- C2
- Designing according to EN 14917

ADVICE : Our opinion and our advice are not guaranteed and MERXTRADE shall not be liable for the consequences of damages. The customer must check the right choice of the products with the real service conditions.