

3 PIECES BALL VALVE FLANGED PN40



Size : DN 15 to 100 mm
Ends : Flanges R.F. PN40
Min Temperature : -30°C in SS and -20°C in carbon steel
Max Temperature : + 180°C
Max Pressure : 40 Bars
Specifications : 3 pieces type
PTFE seat
Anti blow-out stem
Full bore

Materials : Carbon steel or Stainless steel

3 PIECES BALL VALVE FLANGED PN40

SPECIFICATIONS :

- Full bore
- Anti blow-out stem
- PTFE packing
- PTFE seat
- Locking device
- 3 pieces type
- Flanges R.F. PN 40

USE :

- For all common fluid
- Min and max Temperature Ts : -30°C to + 180°C for stainless steel type **Ref. 731**
- Min and max Temperature Ts : -20°C to + 180°C for carbon steel type **Ref. 730**
- Max Pressure PN : 40 bars (see graph)

PRESSURE / TEMPERATURE GRAPH (STEAM EXCLUDED) :

**PRESSURE
BAR**

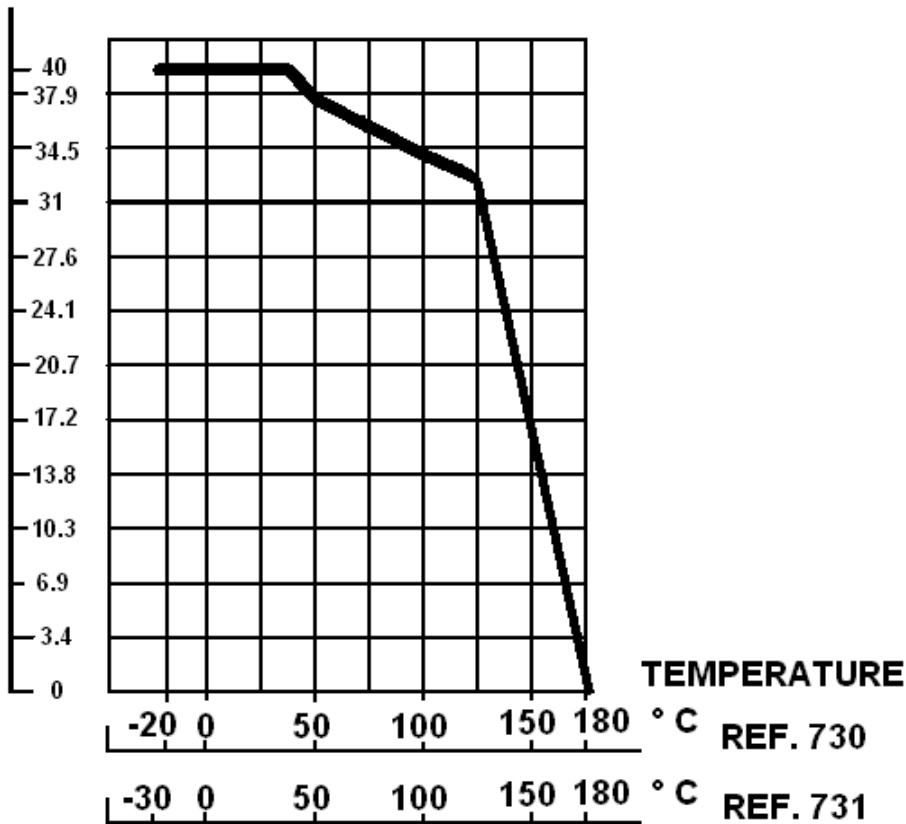

3 PIECES BALL VALVE FLANGED PN40

RANGE :

- Carbon steel Ref. 730 DN 15 to DN 100
- Stainless steel Ref. 731 DN 15 to DN 100

ENDS :

- Flanges R.F. PN40

MATERIALS :

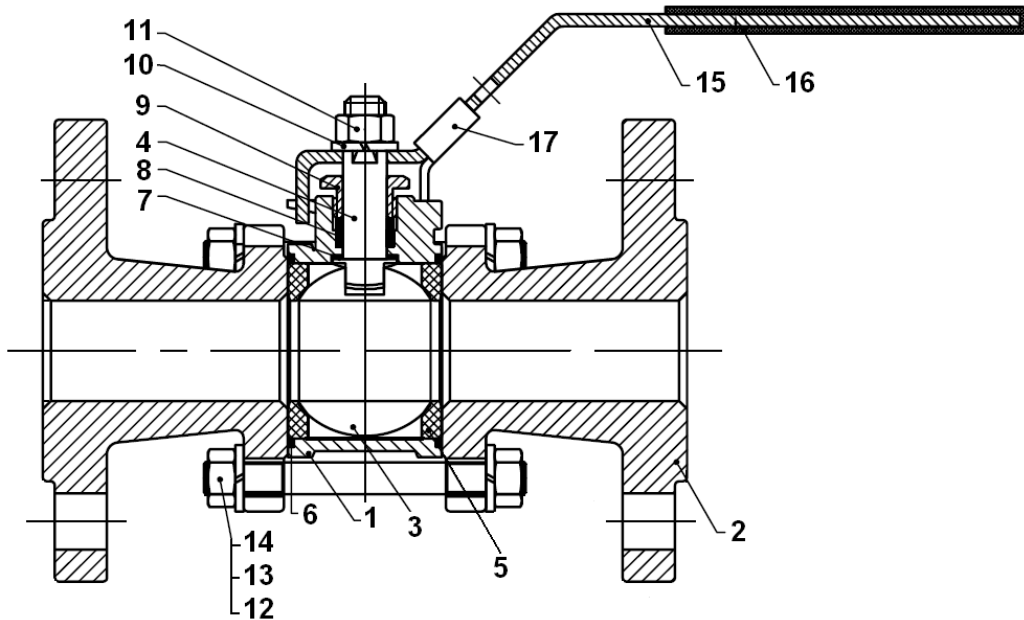

Item	Designation	Materials 730	Materials 731
1	Body	ASTM A216 WCB	ASTM A351 CF8M
2	Ends	ASTM A216 WCB	ASTM A351 CF8M
3	Ball	SS 304	ASTM A351 CF8M
4	Stem		SS 304
5*	Seat		PTFE
6*	Body seal		PTFE
7*	Ring		PTFE
8*	Packing		PTFE
9	Gland		SS 304
10	Handle washer		SS 304
11	Handle nut		SS 304
12	Bolt		SS 304
13	Nut		SS 304
14	Washer		SS 304
15	Handle		SS 304
16	Handle cover		Plastic
17	Locking device		SS 304

(* : included in gaskets kit)

3 PIECES BALL VALVE FLANGED PN40

SIZE (in mm) :

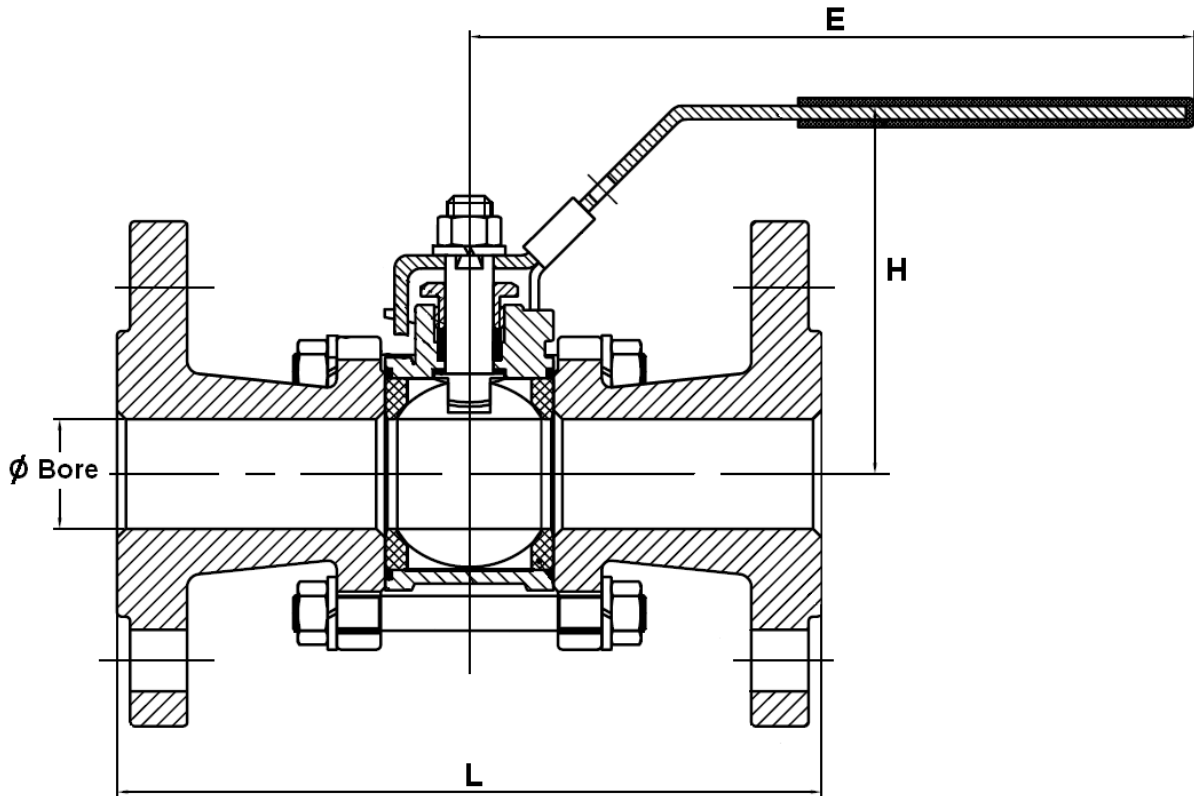

Ref.	DN	15	20	25	32	40	50	65	80	100
730 / 731	Ø Bore	15	20	25	32	38	50	65	80	100
	L	130	150	160	180	200	230	290	310	350
	E	136	136	165	165	200	200	302	302	329
	H	68	72	84	93	99	109	138	150	180
	Weight (Kg)	2.25	3.5	4.3	6.25	7.65	10.9	16.5	24.2	35.4

3 PIECES BALL VALVE FLANGED PN40

FLANGES SIZE (in mm):

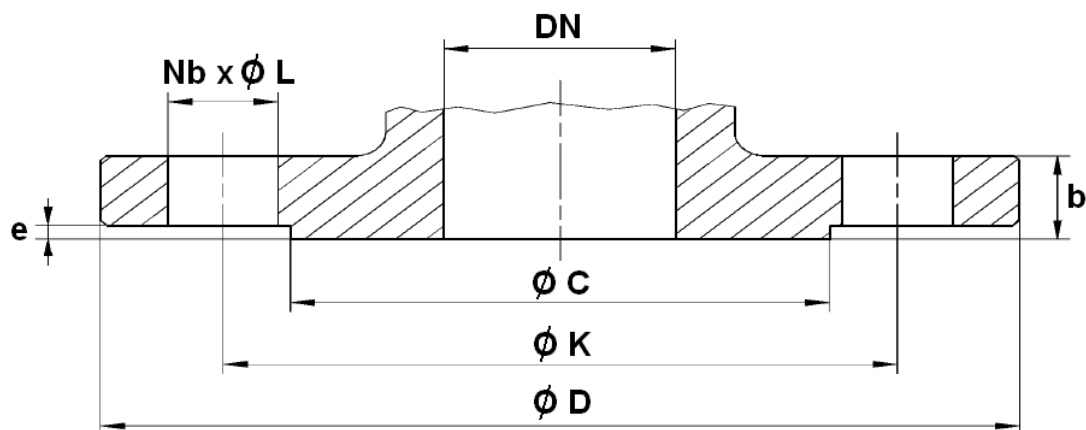

DN	15	20	25	32	40	50	65	80	100
Ø C	46	56	65	76	84	99	118	132	156
Ø D	95	105	115	140	150	165	185	200	235
Ø K	65	75	85	100	110	125	145	160	190
Nb x Ø L	4 x 14	4 x 14	4 x 14	4 x 18	4 x 18	4 x 18	8 x 18	8 x 18	8 x 22
b	14	16	16	18	18	20	22	24	24
e	2	2	3	3	3	3	3	3	3

3 PIECES BALL VALVE FLANGED PN40

FLOW COEFFICIENT Kv (in m³ / h) :

DN	15	20	25	32	40	50	65	80	100
Kv (m ³ / h)	9.5	18.1	30.2	49.3	69.2	129.7	229.2	359	674.6

TORQUE VALUE (in Nm without safety coefficient) :

DN	15	20	25	32	40	50	65	80	100
Torque (Nm)	5.4	7.8	10.6	15	20	28	51	78	113

BOLT TIGHTENING TABLE (In Nm) :

DN	15	20	25	32	40	50	65	80	100
Torque (Nm)	6.9	9.8	9.8	11.8	15.7	20.6	54.9	73.5	94.1

STANDARDS :

- Fabrication according to ISO 9001 : 2000
- DIRECTIVE 97/23/CE : CE N° 0036
Risk Category II
- Tests according to EN 12266-1, A range
- Flanges R.F. according to EN 1092-1 PN40
- Length according to EN 558-1 series 28 (NF 29355 DIN 3202 F1)

ADVICE : Our opinion and our advice are not guaranteed and MXT shall not be liable for the consequences of damages. The customer must check the right choice of the products with the real service conditions.

3 PIECES BALL VALVE FLANGED PN40

INSTALLATION AND MAINTENANCE

BEFORE INSTALLATION :

Pipe-line must be cleaned and free from residual of weldings,rubbish,shaving and every kind of extraneous materials.
Pipe-line must be perfectly aligned and their support properly dimensioned so that there's no external constraint.

To tighten the ends,use the appropriate tool.
Use the right bolt tightening so that the ends won't be damaged.

INSTALLATION OF THE CENTRAL PART

During the installation of the central part , tighten bolts according to the table below.Tighten bolts in cross.

BOLT TIGHTENING TABLE (in Nm) :

DN	15	20	25	32	40	50	65	80	100
Torque (Nm)	6.9	9.8	9.8	11.8	15.7	20.6	54.9	73.5	94.1

CLEANING AND TESTS

Keep closed the valves during the cleaning operation so that there's no impurities between the ball and the body.

Tests under pressure must be done with a cleaned pipe-line.

Open partially the valve for tests. Pressure test do not exceed the valve specifications according to EN 12266-1.

MAITENANCE

It's recommended to operate the valve (open and close) 1 to 2 times per year.

When intervention on the valve, be sure there's no pressure in the pipe-line, there's no fluid in it,and that it is isolated.
The temperature must be low enough to operate without risks.
If there's a corrosive fluid,inert installation before intervention.

When the valve is under pressure :
If there's a leakage between the body and the ends, tighten bolts according to the above table

If there's a leakage at the packing, tighten it slightly so that the leakage disappears.

MAINTENANCE OPERATION IN WORKSHOP

REPLACEMENT OF SEAT GASKETS AND PACKING.

The central part must be removed.
Turn the ball at 45° and removed the seat gaskets.
Operate the valve in closed position to removed the ball.Verify the surface of the ball has no impacts and no scores.
If there are important scores or impatcs,replace the ball.
Clean inside the body valve and remove the impurities.
To replace the packing,remove the handle,unscrew the gland nut, extract the stem by the inside of the valve.
Clean the paking seat.
Reassemble thrust washer on stem, introduce stem by the inside of the valve, reassemble packing with packing nut,reassemble hand washer,hand nut and the handle.
Turn stem in closed position and insert the ball.
Then turn the ball in opened position and reassemble the seat.
Place the valve on the installation,tighten bolts according to the above table.
Then proceed to the tests in the same way that the first installation.