

2 PIECES SPLIT BODY BALL VALVE FLANGED PN16/40 ICP DIN 3202 F4/F5

2 pieces carbon steel split body ball valve ICP with full bore for Chemical industries, petrochemical industries, hydraulic installation, heating, water distribution, compressed air.

Ball valve with firesafe certificate ISO 10497 to reduce risks in case of fire.

Fugitive emission according to EN 15848-1 :2006 for an excellent tightness on the stem and to prevent external leakage.

PTFE seat for a temperature up to +230°C.

Compatible with explosive atmosphere, ATEX Zone 1&21 and Zone 2&22 thanks to the antistatic device.

Handling possible with gearbox or stainless steel handle.

Thanks to the ISO 5211 plate, an actuator can be installed on the valve.



Size : DN15 to DN200

Connection : Flanged PN16/40 RF

Min Temperature : -20°C

Max Temperature : +230°C

Max Pressure : 40 bars up to DN50, 16 bars over

Specifications : Antistatic device, ATEX

ISO 5211 mounting pad

Anti blow-out stem, full bore

Fugitive Emissions EN 15848-1 :2006

Fire Safe ISO 10497 :2004

Materials : Carbon Steel EN 1.0619

2 PIECES SPLIT BODY BALL VALVE FLANGED PN16/40 ICP DIN 3202 F4/F5

SPECIFICATIONS :

- Full bore
- Anti blow-out stem
- PTFE seat
- Locking device
- ISO 5211 mounting pad
- 2 pieces type (Split body)
- PN40 Flanges R.F. up to DN50, PN16 over
- Antistatic device
- Fire safe ISO 10497 : 2004
- Fugitive emissions EN 15848-1 : 2006
- Graphite packing + FKM O ring on stem
- With exhaust hole in the ball (located in the top of the ball to avoid overpressure in it)
- Blue painting colour RAL 5009 or Black painting colour RAL 9004, 5-15 microns thickness

USE :

- Chemical industries, petrochemical industries, hydraulic installation, heating, water distribution, compressed air
- Min and max Temperature Ts : -20°C to + 230°C
- Max Pressure Ps : 40 bars up to DN50, 16 bars over (see graph)
- Vacuum 10⁻² torr
- Compressed air (ambient temperature) : 8 bars maximum
- Steam : 12 bars maximum

PRESSURE / TEMPERATURE GRAPH (STEAM EXCLUDED) :

PRESSURE

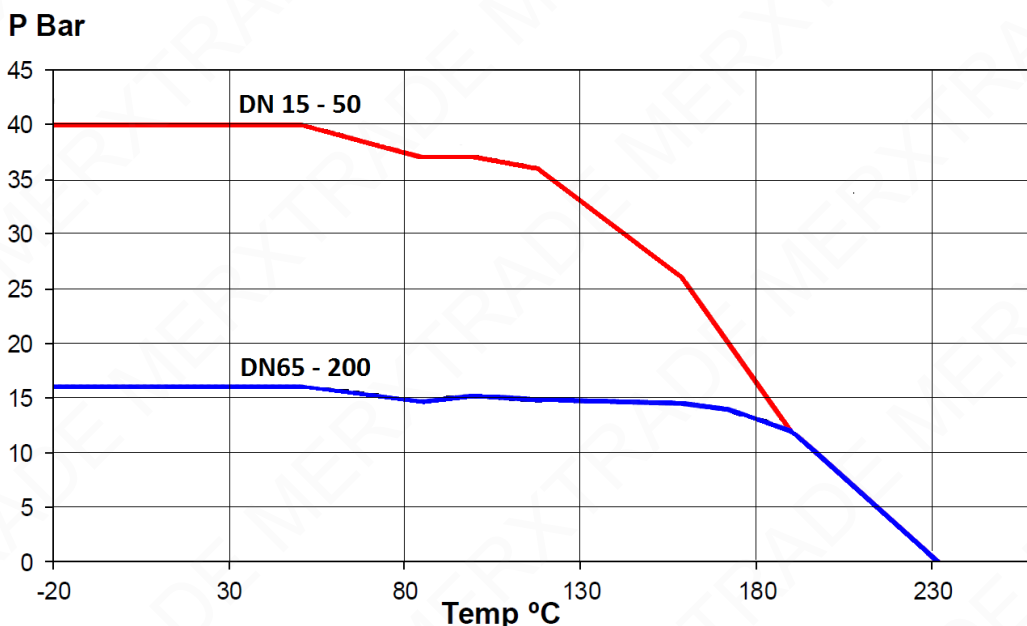

2 PIECES SPLIT BODY BALL VALVE FLANGED PN16/40 ICP DIN 3202 F4/F5

FLOW COEFFICIENT Kvs (in m3 / h) :

DN	15	20	25	32	40	50	65	80	100	125	150	200
Kvs (m3 / h)	20	40	75	130	170	270	550	1000	1650	3000	4200	9000

TORQUE VALUE (in Nm without safety coefficient) :

DN	15	20	25	32	40	50	65	80	100	125	150	200
Torque (Nm)	8	12	14	22	27	50	51	77	116	159	215	493

RANGE :

- Carbon steel body ball valve **Ref. 752** DN 15 to DN 200
- Possible with gearbox **Ref. 9830221-9830222 and 9830266-267** from DN 100 to DN 200
- ASTM A351 CF8M handle **Ref. 9812090-9812097** from DN 15 to DN 200

ENDS:

- PN40 Flanges R.F. up to DN50, PN16 over

2 PIECES SPLIT BODY BALL VALVE FLANGED PN16/40 ICP DIN 3202 F4/F5

VALVE MATERIALS :

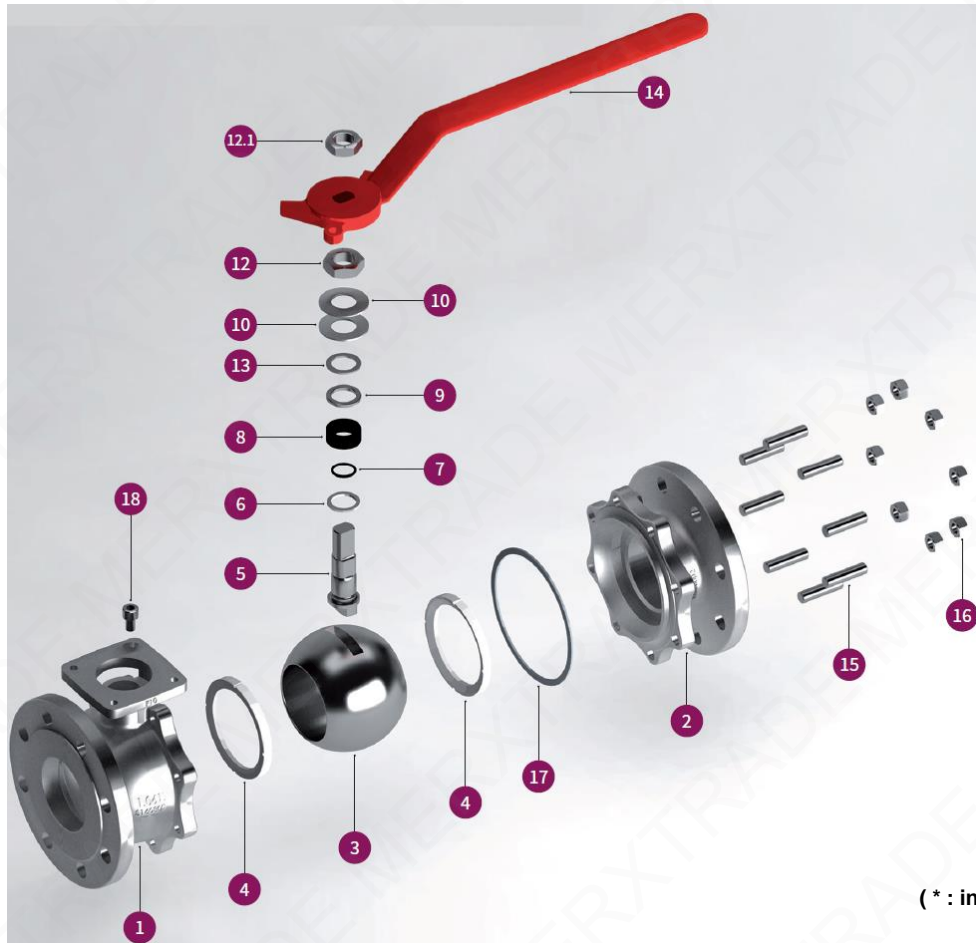

(* : included in gaskets kit)

Item	Designation	Materials
1	Body	Carbon steel EN 1.0619
2	Ends	
3	Ball	ASTM A351 CF8M
4*	Seat	PTFE
5	Stem	ASTM A479 type 316
6*	Stem thrust seal	PTFE filled with 25% glass
7*	Stem O ring	FKM
8*	Gland Packing	Graphite
9	Gland	AISI 303
10	Elastic ring	Inconel 718
12	Gland nut	AISI 303
12.1	Handle nut	AISI 303
13	Antifriction washer	PTFE filled with 25% glass
14	Handle	Nodular iron
15	Stud	A 193 Gr. B7M
16	Nut	A 194 Gr. 2HM
17*	Spiralwound gasket	SS 316L + PTFE + Graphite
18	Bolt	A2

2 PIECES SPLIT BODY BALL VALVE FLANGED PN16/40 ICP DIN 3202 F4/F5

GEARBOX MATERIALS :

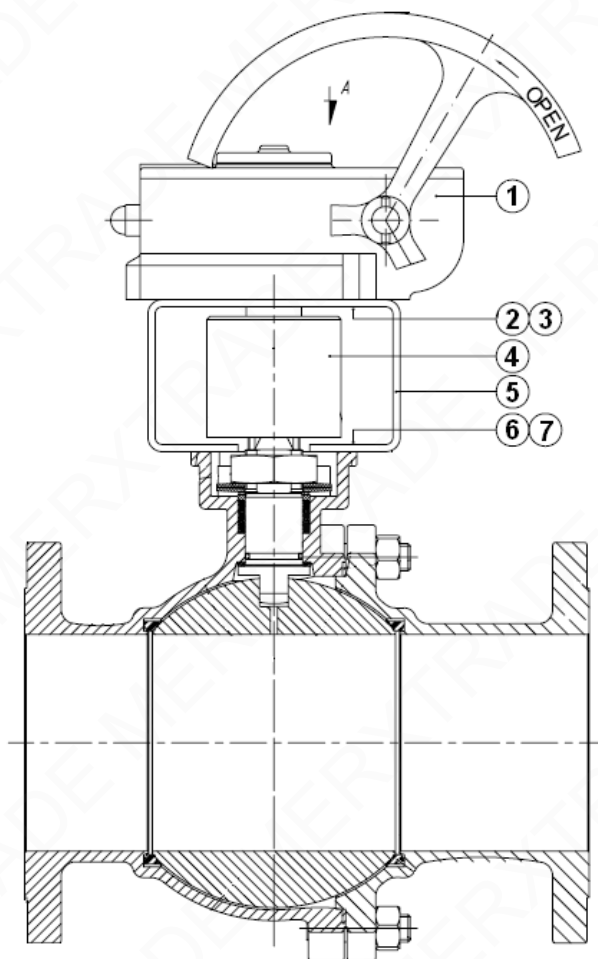

Item	Designation	Materials
1	Gearbox	Painted steel
2	Screw	DIN 912 A2
3	Washer	DIN 912 A2
4	Coupling	Stainless steel
5	Mounting bracket	Stainless steel
6	Screw	DIN 912 A2
7	Washer	DIN 912 A2

2 PIECES SPLIT BODY BALL VALVE FLANGED PN16/40 ICP DIN 3202 F4/F5

VALVE SIZE (in mm) :

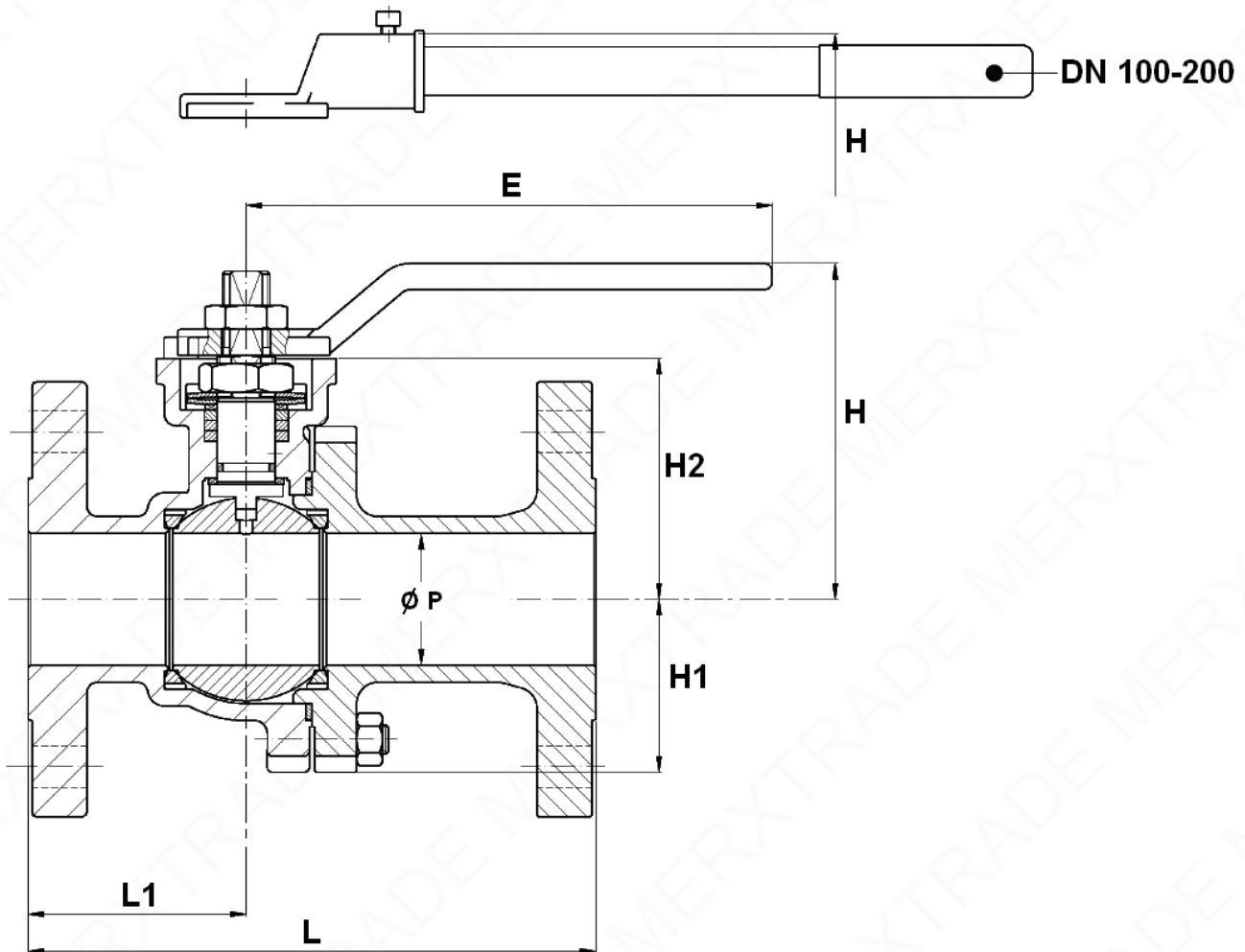

DN	15	20	25	32	40	50	65	80	100	125	150	200
Ø P	15	20	25	32	40	50	65	78	100	125	151	203
L	115	120	125	130	140	150	170	180	190	325	350	400
L1	53	52	52	54	55	61	72	73	83	120	135	200
E	170	170	170	170	215	215	335	430	466	680	680	845
H	68	70	86	89.5	122.5	127.5	140	190	192.5	240	259	319
H1	31	33	39	43	48	63	78	87	108	134	152	202
H2	41	43	58.5	63.5	86.5	91.5	104	118.5	144	184	203	250
Weight (Kg)	2.4	3.2	4.1	5.8	8.1	10.6	13.3	19.1	25.6	47.6	63.5	115.3
Ref.	752015	752020	752025	752032	752040	752050	752065	752080	752100	752125	752150	752200

2 PIECES SPLIT BODY BALL VALVE FLANGED PN16/40 ICP DIN 3202 F4/F5

ISO MOUNTING PAD AND STEM SIZE (in mm) :

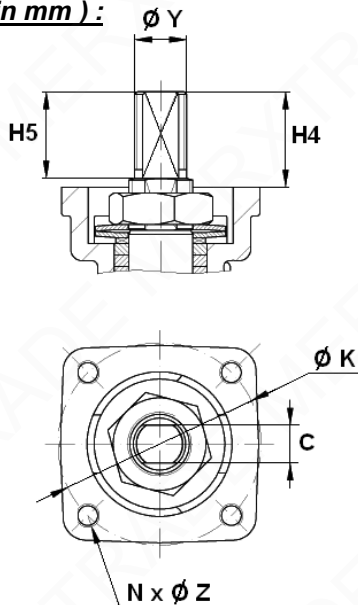

DN	15	20	25	32	40	50	65	80	100	125	150	200
H4	18	18	22	22	33	33	34	34	45	56	56	69
H5	11	11	21	21	32	32	33	33	43.5	54.5	54.5	67
C	7	7	8	8	12	12	15	15	19	24	24	32
Ø Y	M10	M10	M12	M12	M18	M18	M22	M22	M28	M36	M36	M48
Ø K	50	50	50	50	70	70	70	102	102	125	125	140
ISO	F05	F05	F05	F05	F07	F07	F07	F10	F10	F12	F12	F14
N x Ø Z	4 x M6	4 x M6	4 x M6	4 x M6	4 x M8	4 x M8	4 x M8	4 x M10	4 x M10	4 x M12	4 x M12	4 x M16

FLANGES SIZE (in mm) :

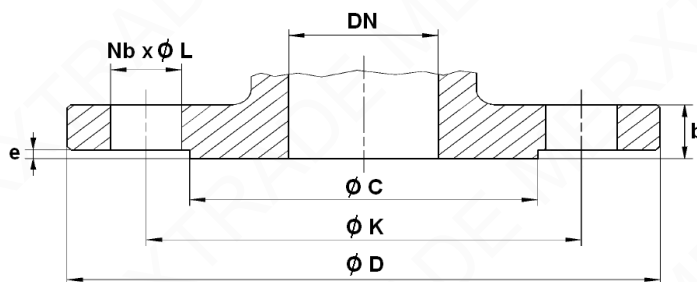

DN	15	20	25	32	40	50	65	80	100	125	150	200
Ø C	45	58	68	78	88	102	122	138	158	188	212	268
Ø D	95	105	115	140	150	165	185	200	220	250	285	340
Ø K	65	75	85	100	110	125	145	160	180	210	240	295
Nb x Ø L	4 x 14	4 x 14	4 x 14	4 x 18	4 x 18	4 x 18	4 x 18	8 x 18	8 x 18	8 x 18	8 x 22	12 x 22
b	16	18	18	18	18	20	18	20	20	22	22	23
e	2	2	2	2	2	2	2	2	2	2	2	2

2 PIECES SPLIT BODY BALL VALVE FLANGED PN16/40 ICP DIN 3202 F4/F5

GEARBOX SIZE (in mm) :

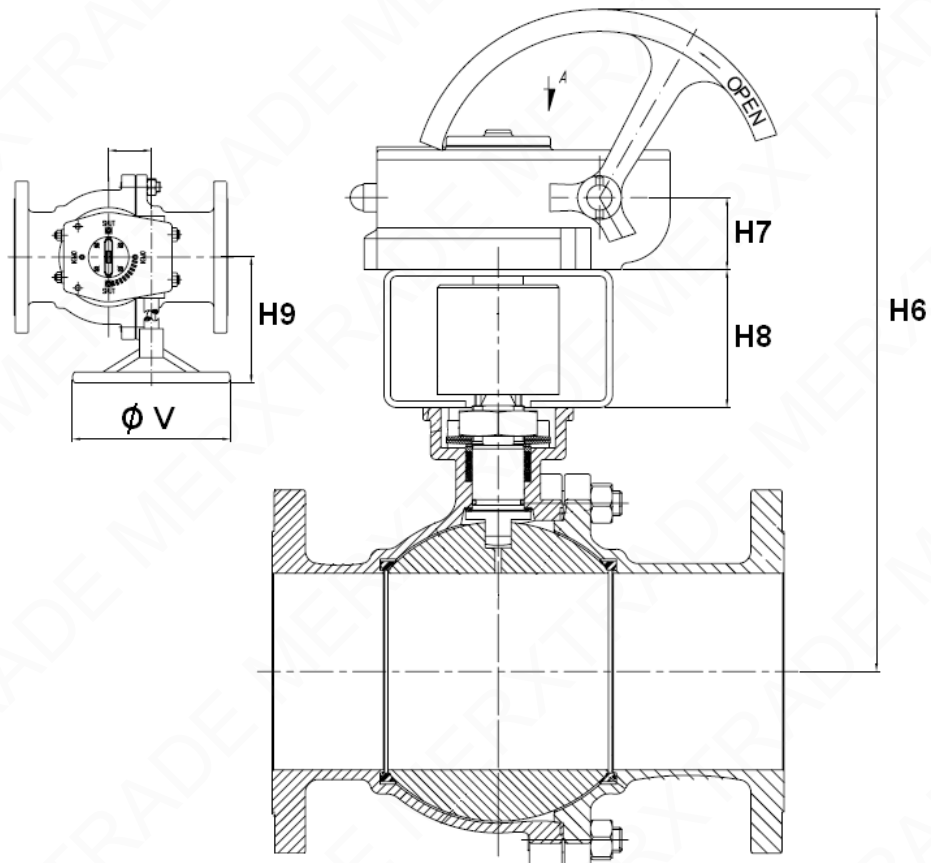

DN	100	125	150	200
H6	521.5	561.5	596.5	643.5
H7	55	55	55	55
H8	90	90	107	107
H9	229	229	229	229
Ø V	465	465	465	465
Ref. gearbox	9830221	9830222	9830266	9830267
Weight gearbox (Kg)	17.8	17.8	19.5	19.7
Weight gearbox + valve (Kg)	43.4	65.4	83	135

2 PIECES SPLIT BODY BALL VALVE FLANGED PN16/40 ICP DIN 3202 F4/F5

STAINLESS STEEL HANDLE SIZE (in mm) :

DN 15 - 80

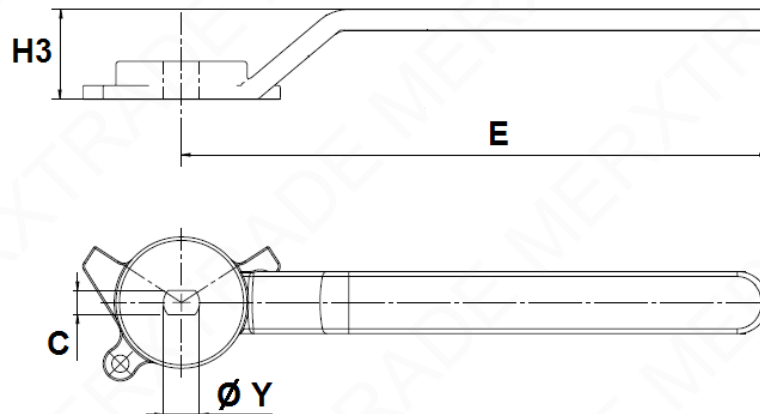

DN 100 - 200

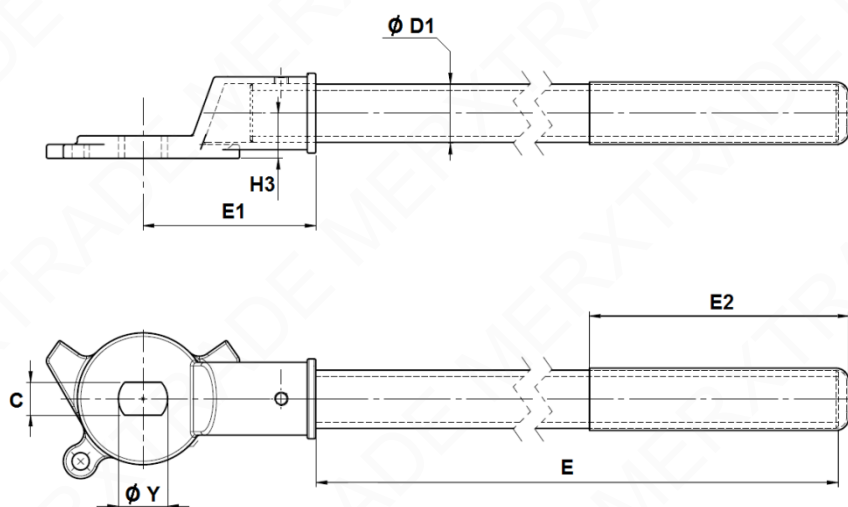

DN	15-20	25-32	40-50	65	80	100	125-150	200
E	170	170	215	335	430	375	578	730
E1	-	-	-	-	-	100	115	140
E2	-	-	-	-	-	120	200	200
H3	26	26	35	35	71	26	30	36
Ø D1	-	-	-	-	-	26.8	33	42
C	7	8	12	15	15	19	24	32
Ø Y	10.5	12.5	18.5	22.5	22.5	28.5	36.5	48.5
Ref.	9812090	9812091	9812092	9812093	9812094	9812095	9812096	9812097

2 PIECES SPLIT BODY BALL VALVE FLANGED PN16/40 ICP DIN 3202 F4/F5

STANDARDS :

- Manufacturer certified ISO 9001:2015
- DIRECTIVE 2014/68/EU : CE N° 0035
Risk Category III module H
- Certificate 3.1 on request
- Valve designing according to EN 1983 – ISO 17292
- Pressure Tests according to EN 12266-1, Rate A
- Marking according to EN 19
- Fire safe according to ISO 10497 : 2004
- Fugitive Emissions according to EN 15848-1 : 2006
- Flanges R.F. according to EN 1092-1 PN16/40
- ISO 5211 mounting pad and stem size according to EN 15081
- Length according to EN 558 series 27 (DIN 3202 F4 up to DN100, DIN 3202 F5 over)
- ATEX Group II Category 2 G/2Dc Zone 1 & 21 Zone 2 & 22 (optional marking) according to directive 2014/34/EU

ADVICE : Our opinion and our advice are not guaranteed and MERXTRADE shall not be liable for the consequences of damages. The customer must check the right choice of the products with the real service conditions.

2 PIECES SPLIT BODY BALL VALVE FLANGED PN16/40 ICP DIN 3202 F4/F5

INSTALLATION INSTRUCTIONS

GENERAL GUIDELINES :

- Ensure that the valves to be used are appropriate for the conditions of the installation (type of fluid, pressure and temperature).
- Be sure to have enough valves to be able to isolate the sections of piping as well as the appropriate equipment for maintenance and repair.
- Ensure that the valves to be installed are of correct strength to be able to support the capacity of their usage.
- **Installation of all circuits should ensure that their function can be automatically tested on a regular basis (at least two times a year).**

INSTALLATION INSTRUCTIONS :

- **Before installing the valves, clean and remove any objects from the pipes** (in particular bits of sealing and metal) which could obstruct and block the valves.
- **Ensure that both connecting pipes either side of the valve (upstream and downstream) are aligned (if they're not, the valves may not work correctly).**
- **Make sure that the two sections of the pipe (upstream and downstream) match, the valve unit will not absorb any gaps. Any distortions in the pipes may affect the tightness of the connection, the working of the valve and can even cause a rupture.** To be sure, place the kit in position to ensure the assembling will work.
- **If sections of piping do not have their final support in place, they should be temporarily fixed. This is to avoid unnecessary strain on the valve.**
- Tighten the bolts in cross.
- It's recommended to operate the valve (open and close) 1 to 2 times per year