

3 PIECES BALL VALVE PN63

Size : DN 8 to 100 mm
Ends : Threaded BSP or NPT , Socket or But Welding
Min Temperature : -20°C
Max Temperature : + 180°C
Max Pressure : 63 Bars
Specifications : Anti blow-out stem
Locking device
Full bore

Materials : Carbon or stainless steel

3 PIECES BALL VALVE PN63

SPECIFICATIONS :

- Full bore
- Anto blow-out stem
- PTFE packing
- Locking device
- Stem extension in SS 304 (option)
- Blue handle cover possible

USE :

- For all common fluids
- Min and max Temperature Ts : -20°C to + 180°C
- Max Pressure PN : 63 bars according to DN (see graph)

PRESSURE / TEMPERATURE GRAPH (STEAM AND COMPRESSED AIR EXCLUDED) :

PRESSURE

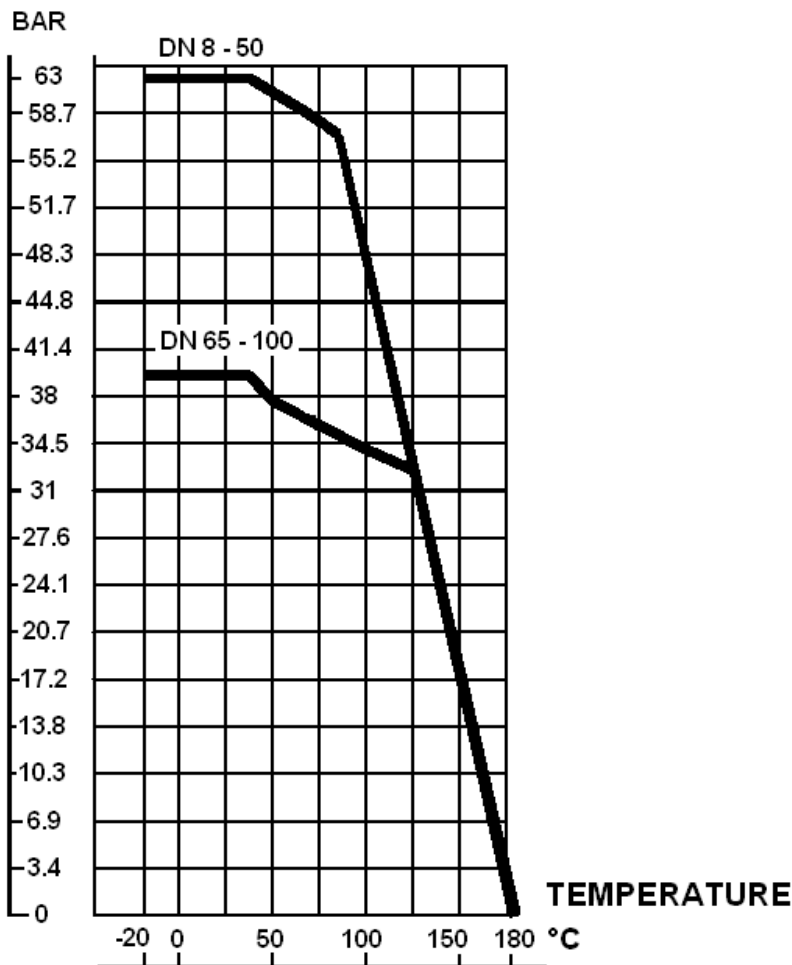

3 PIECES BALL VALVE PN63

RANGE :

- Carbon steel Ref. **796/7961/797/798** from DN 8 to DN 100
- Stainless steel Ref. **790/791/792/744** from DN 8 to DN 100
- Blue handle cover Ref. **9830444-9830449** from DN 8 to DN 100

ENDS :

- Female / female threaded BSP Ref. **790/796**
- Female / female threaded NPT Ref. **744/7961**
- Socket Welding Ref. **792/798**
- But welding Ref. **791/797**

MATERIALS :

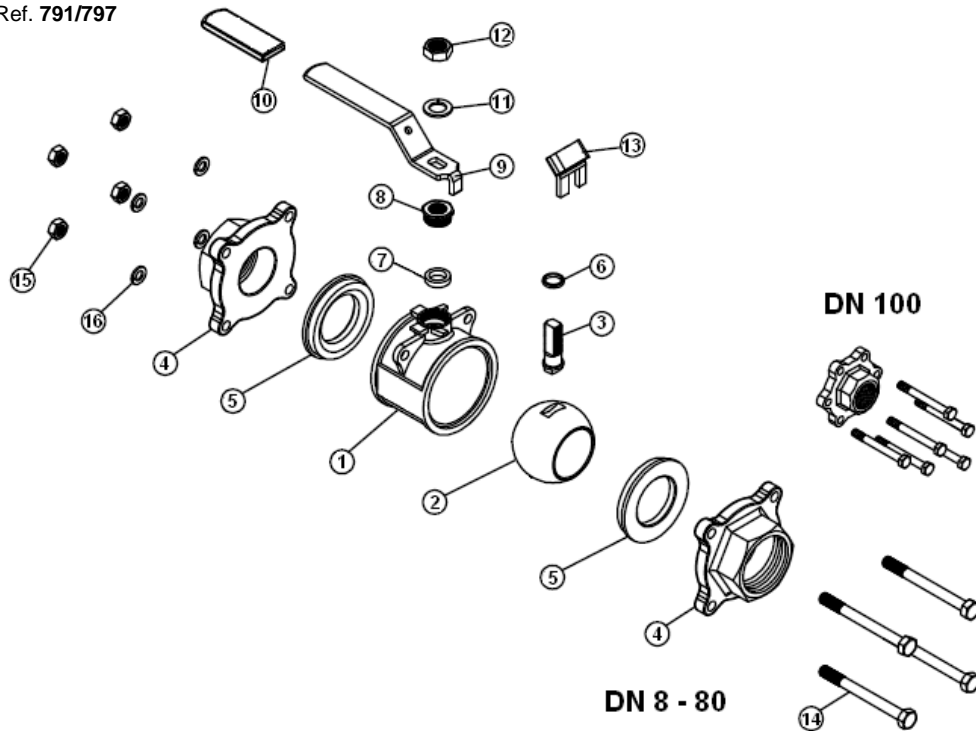

Item	Designation	Materials 796/7961/797/798	Materials 790/791/792/744
1	Body	ASTM A216 WCB	SS 316
2	Ball	SS 304	SS 316
3	Stem	SS 304	SS 316
4	Ends	ASTM A216 WCB	SS 316
5*	Seat	PTFE filled with 15% glass	
6*	Thrust washer	PTFE	
7*	Packing	PTFE	
8	Packing nut	SS 304	
9	Handle	SS 304	
10	Handle cover	Plastic	
11	Handle washer	SS 304	
12	Handle nut	SS 304	
13	Locking device	SS 304	
14	Bolt	SS 201	
15	Bolt nut	SS 304	
16	Bolt washer	SS 304	

(* : Included in gaskets kit)

3 PIECES BALL VALVE PN63

SIZE THREADED STAINLESS STEEL TYPES (in mm) :

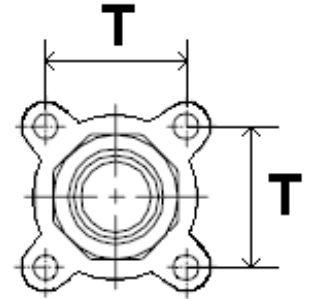
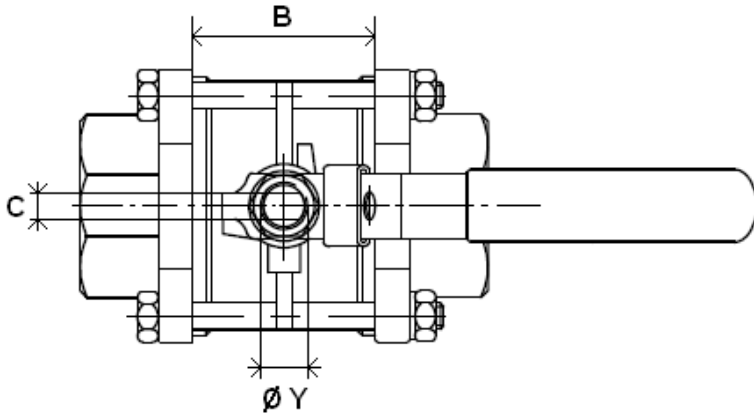

DN 1/4" - 3"

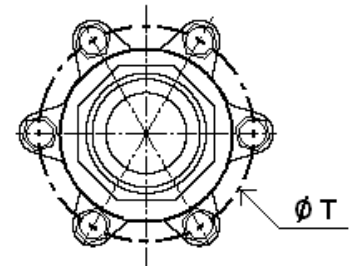
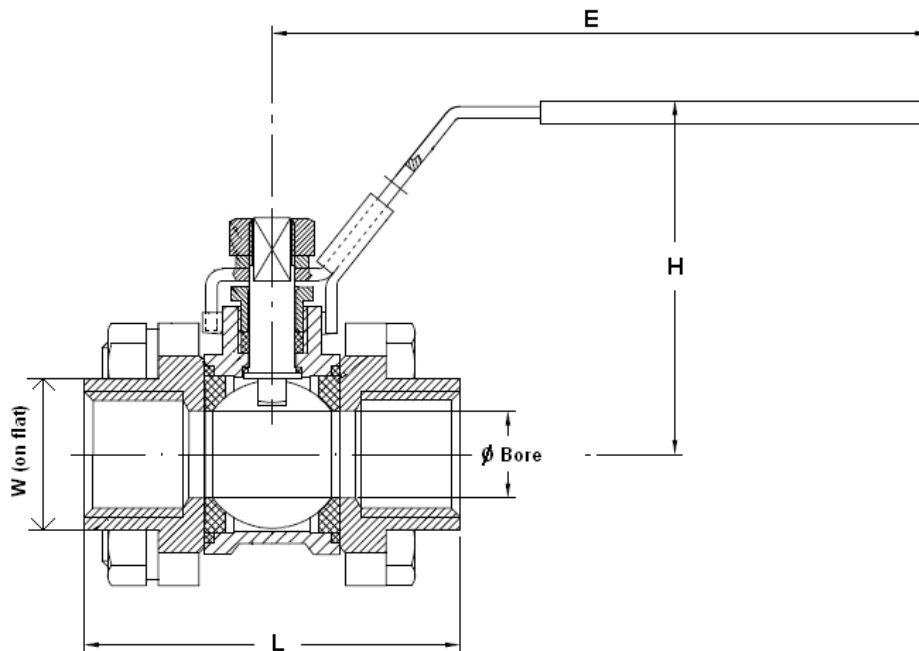

DN 4"

Stem size :

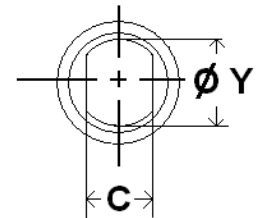

	DN	1/4"	3/8"	1/2"	3/4"	1"	1"1/4"	1"1/2"	2"	2"1/2"	3"	4"
Ref.	Ø Bore	9.2	12.8	15	20	25	32	38	50	65	80	100
	L	60	60	63	70	82	96	107	124	164.6	182.7	217.7
790	B	22	22	23.3	28	34	43	49	62.4	88.1	100.2	119.1
	E	108	108	113	113	135	135	160	160	230	230	335
744	H	52	52	63	68	79	88	97	108	128	140	172
	Ø Y	8	8	8	8	10	10	12	12	14	14	20
Threaded	C	5	5	5	5	6.5	6.5	8.5	8.5	9.8	9.8	16
	T	27.2	27.2	31.8	40	45	53	63.3	78.8	98.3	116.6	200.5
	W	18	22	26	33	40	48	55	67	84.5	101	127
	Weight (Kg)	0.33	0.34	0.49	0.64	0.96	1.37	2.2	3.75	6.85	10.2	20.5

3 PIECES BALL VALVE PN63

SIZE THREADED CARBON STEEL TYPES (in mm) :

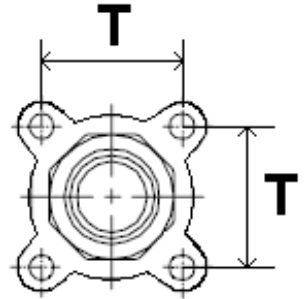
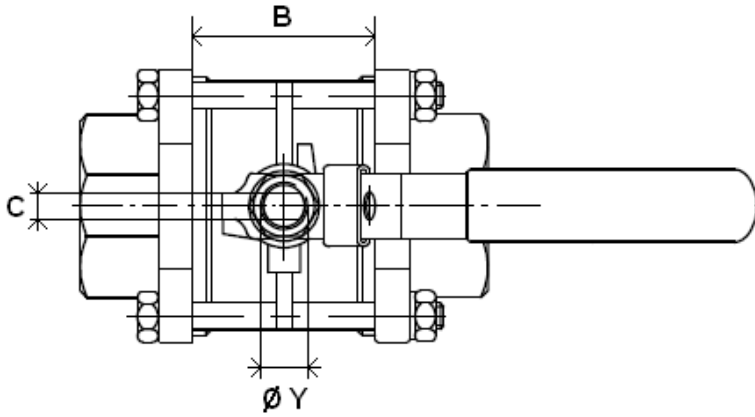

DN 1/4" - 3"

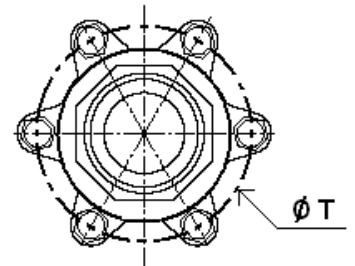
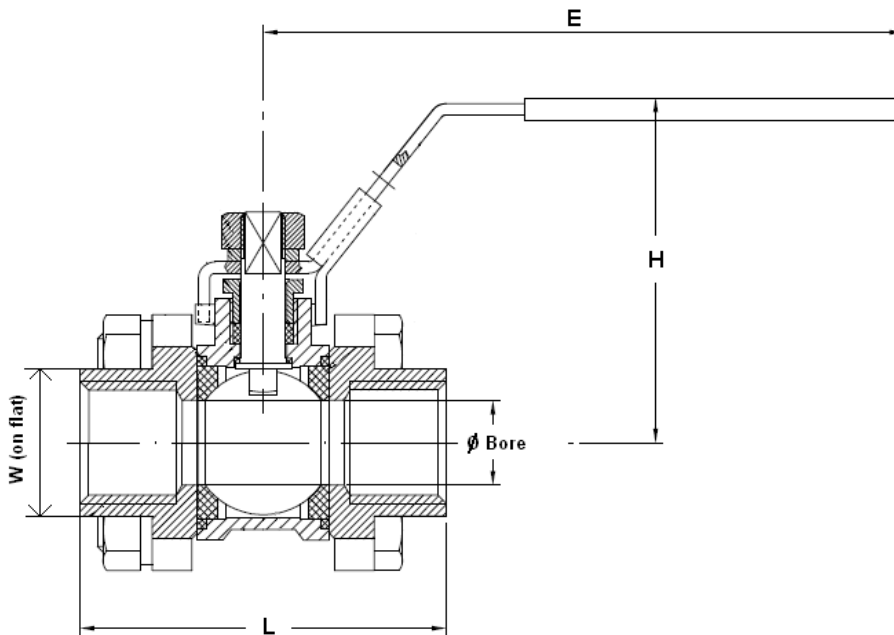

DN 4"

Stem size :

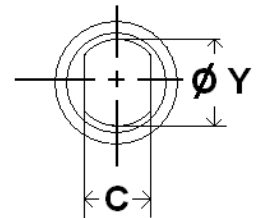

	DN	1/4"	3/8"	1/2"	3/4"	1"	1"1/4"	1"1/2"	2"	2"1/2"	3"	4"
Ref.	Ø Bore	9.2	12.8	15	20	25	32	38	50	65	80	100
	L	59	60	65.5	76.5	86.2	103.1	118	131.5	164.5	182.7	229.6
796	B	20	22	23.3	30.8	37.8	47	57	68	86.1	98.2	126.1
	E	108	108	113	113	135	135	160	160	230	230	335
7961	H	52	52	63	68	79	88	97	108	128	140	172
	Ø Y	8	8	8	8	10	10	12	12	14	14	20
Threaded	C	5	5	5	5	6.5	6.5	8.5	8.5	10	10	16
	T	25	28	32	40	45	53	64	79	98	116	198
	W	20	22	26	33	40	48	55	67	87	101	130
	Weight (Kg)	0.33	0.34	0.52	0.78	1.08	1.64	2.78	4.27	8.2	13	26

3 PIECES BALL VALVE PN63

SIZE STAINLESS STEEL BUT WELDING TYPES (in mm) :

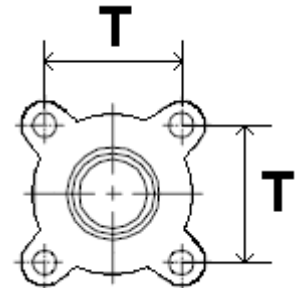
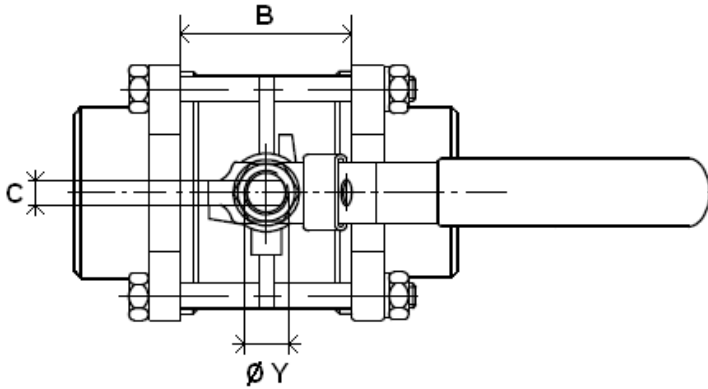

DN 1/4" - 3"

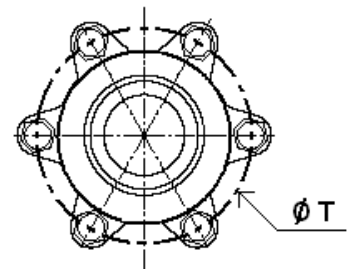
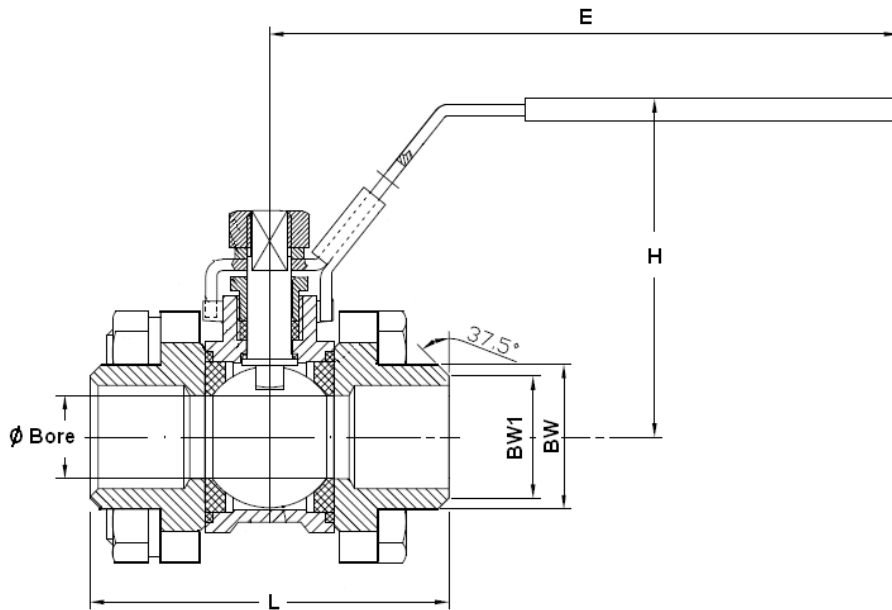

DN 4"

Stem size :

	DN	1/4"	3/8"	1/2"	3/4"	1"	1"1/4"	1"1/2"	2"	2"1/2"	3"	4"
Ref.	Ø Bore	9.2	12.8	15	20	25	32	38	50	65	80	100
	L	60	60	63	70	82	96	107	124	162.6	180.7	221.7
	B	22	22	23.3	28	34	43	49	62.4	88.1	100.2	119.1
791	E	108	108	113	113	135	135	160	160	230	230	335
	H	52	52	63	68	79	88	97	108	128	140	172
	Ø Y	8	8	8	8	10	10	12	12	14	14	20
B.W.	C	5	5	5	5	6.5	6.5	8.5	8.5	9.8	9.8	16
	T	27.2	27.2	31.8	40	45	53	63.3	78.8	98.3	116.6	200.5
	BW	14	17.5	22	27.5	34	43	49	61	76.5	90	115
	BW1	12	14.5	17	22.5	28.6	36	43	54	68	84	104
	Weight (Kg)	0.33	0.33	0.49	0.64	0.96	1.37	2.2	3.75	6.85	10.2	20.5

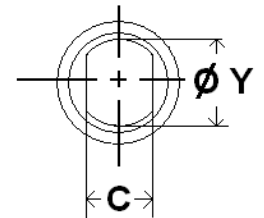

3 PIECES BALL VALVE PN63

SIZE CARBON STEEL BUT WELDING TYPES (in mm) :

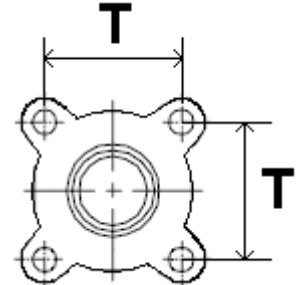
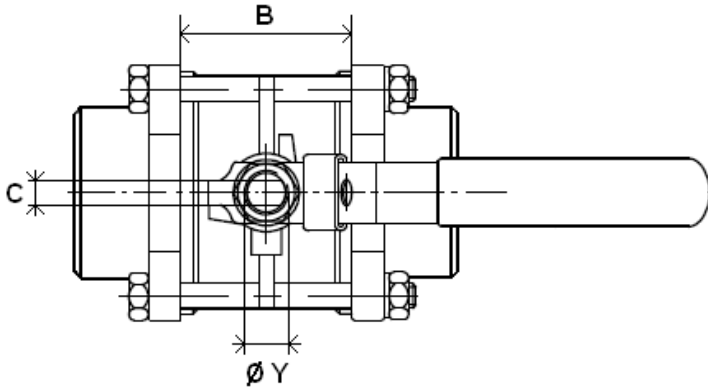

DN 1/4" - 3"

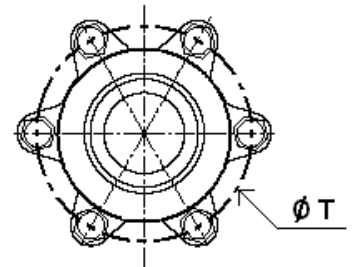
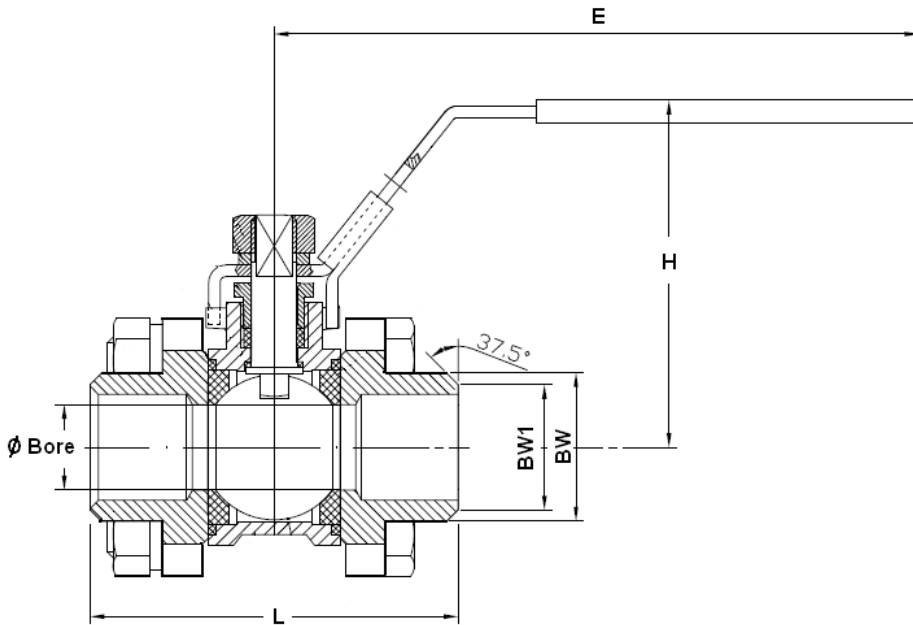

DN 4"

Stem size :

	DN	1/4"	3/8"	1/2"	3/4"	1"	1 1/4"	1 1/2"	2"	2 1/2"	3"	4"
Ref.	Ø Bore	9.2	12.8	15	20	25	32	38	50	65	80	100
	L	59	60	65.5	76.5	86.2	103.1	118	131.5	174.5	192.7	239.6
	B	20	22	23.3	30.8	37.8	47	57	68	96.1	108.2	136.1
797	E	108	108	113	113	135	135	160	160	230	230	335
	H	52	52	63	68	79	88	97	108	128	140	172
	Ø Y	8	8	8	8	10	10	12	12	14	14	20
B.W.	C	5	5	5	5	6.5	6.5	8.5	8.5	10	10	16
	T	25	28	32	40	45	53	64	79	98	116	198
	BW	14	17.5	22	27.5	34	43	49	61	76.5	90	115
	BW1	12	14.5	17	22.5	28.6	36	43	54	68	84	104
	Weight (Kg)	0.33	0.34	0.52	0.78	1.08	1.64	2.78	4.27	8.2	13	26

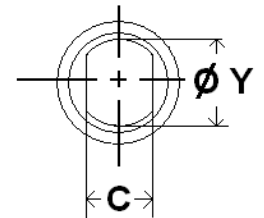

3 PIECES BALL VALVE PN63

SIZE STAINLESS STEEL SOCKET WELDING TYPES (in mm) :

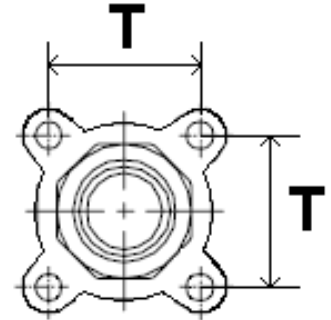
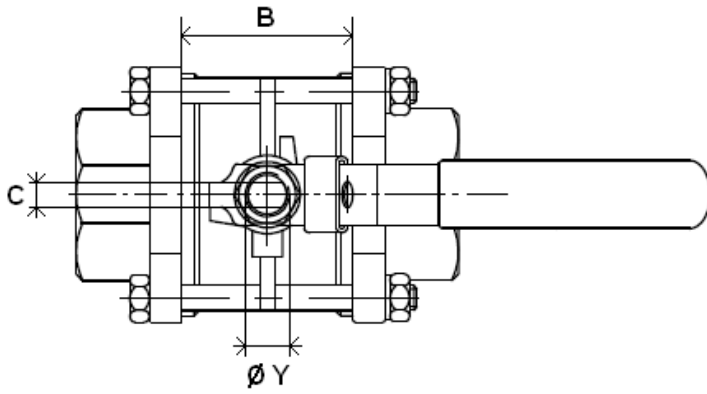

DN 1/4" - 3"

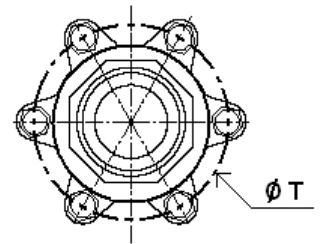
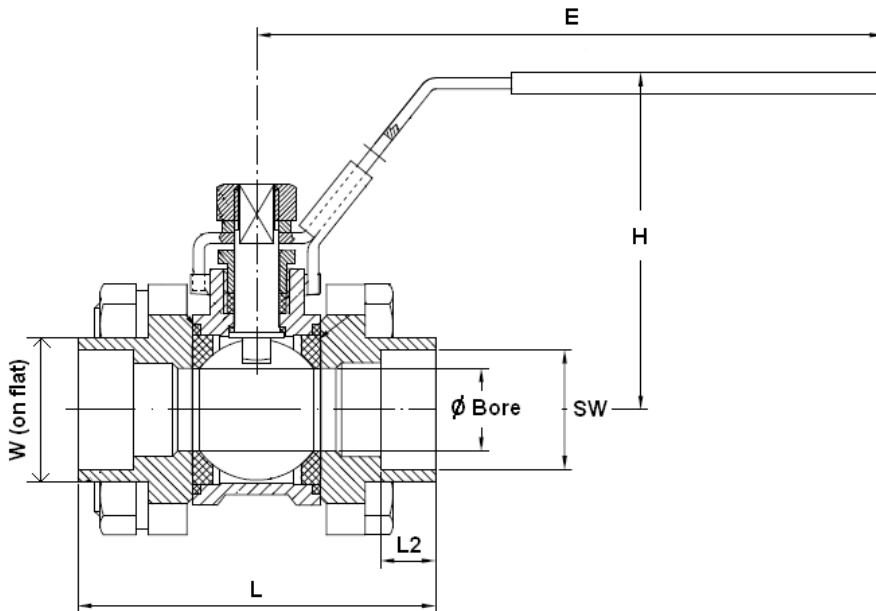

DN 4"

Stem size :

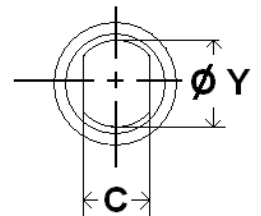

	DN	1/4"	3/8"	1/2"	3/4"	1"	1 1/4"	1 1/2"	2"	2 1/2"	3"	4"
Ref.	Ø Bore	9.2	12.8	15	20	25	32	38	50	65	80	100
	L	60	60	63	70	82	96	107	124	164.6	182.7	217.7
	B	22	22	23.3	28	34	43	49	62.4	88.1	100.2	119.1
	L2	10	10	10	13	13	13	13	16	16	16	19
792	E	108	108	113	113	135	135	160	160	230	230	335
	H	52	52	63	68	79	88	97	108	128	140	172
	Ø Y	8	8	8	8	10	10	12	12	14	14	20
S.W.	C	5	5	5	5	6.5	6.5	8.5	8.5	9.8	9.8	16
	T	27.2	27.2	31.8	40	45	53	63.3	78.8	98.3	116.6	200.5
	W	18	22	26	33	40	48	55	67	84.5	101	127
	SW	14.1	17.6	21.9	27.4	34.2	42.8	48.8	61.1	77	89.9	115.4
	Weight (Kg)	0.33	0.33	0.49	0.64	0.96	1.37	2.2	3.75	6.85	10.2	20.5

3 PIECES BALL VALVE PN63

SIZE CARBON STEEL SOCKET WELDING TYPES (in mm) :

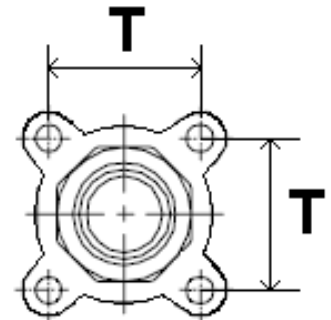
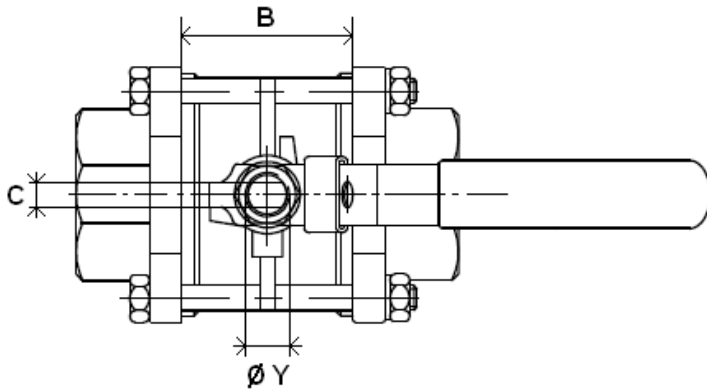

DN 1/4" - 3"

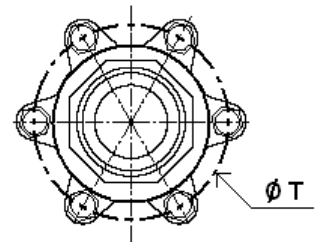
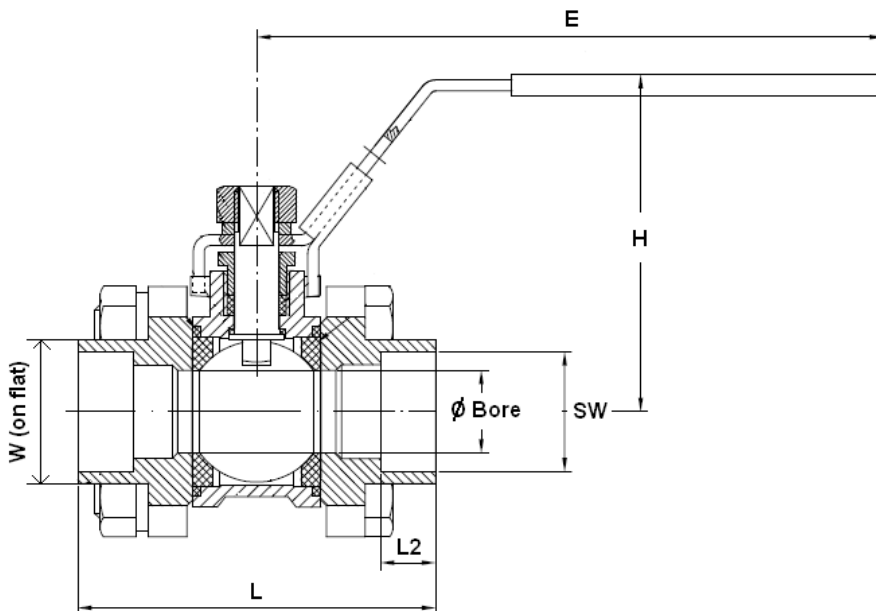

DN 4"

Stem size :

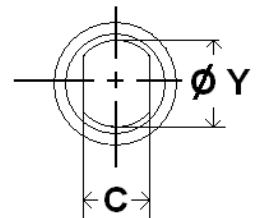

	DN	1/4"	3/8"	1/2"	3/4"	1"	1 1/4"	1 1/2"	2"	2 1/2"	3"	4"
Ref.	Ø Bore	9.2	12.8	15	20	25	32	38	50	65	80	100
	L	59	60	65.5	76.5	86.2	103.1	118	131.5	174.5	192.7	239.6
	B	20	22	23.3	30.8	37.8	47	57	68	96.1	108.2	136.1
	L2	10	10	10	13	13	13	13	16	16	16	19
798	E	108	108	113	113	135	135	160	160	230	230	335
	H	52	52	63	68	79	88	97	108	128	140	172
S.W.	C	5	5	5	5	6.5	6.5	8.5	8.5	10	10	16
	Ø Y	8	8	8	8	10	10	12	12	14	14	20
	T	25	28	32	40	45	53	64	79	98	116	198
	W	20	22	26	33	40	48	55	67	87	101	130
	SW	14.1	17.6	21.9	27.4	34.2	42.8	48.8	61.1	77	89.9	115.4
	Weight (Kg)	0.33	0.33	0.52	0.78	1.08	1.64	2.78	4.27	8.2	13	26

3 PIECES BALL VALVE PN63

STEM EXTENSION (in mm) :

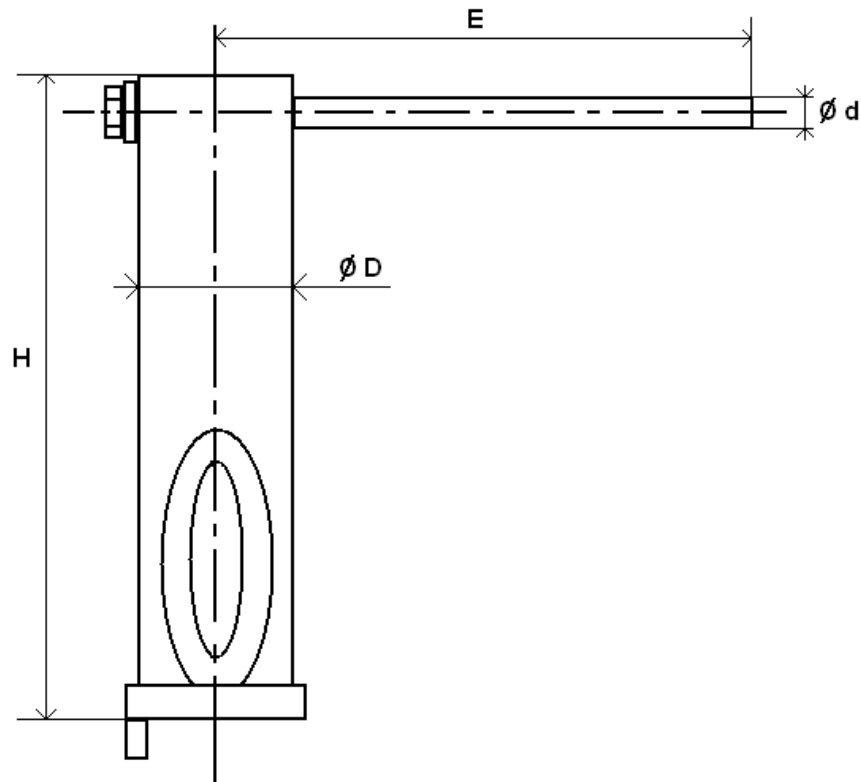

	DN	1/4"	3/8"	1/2"	3/4"	1"	1"1/4"	1"1/2"	2"
Ref.	H	125.5	125.5	125.5	125.5	125.5	125.5	127.5	127.5
	E	125	125	125	125	158	158	190	190
	Ø D	28	28	28	28	32	32	36	36
981060	Ø d	12	12	12	12	14	14	14	14
	Weight (Kg)	0.3	0.3	0.3	0.3	0.4	0.4	0.6	0.6

3 PIECES BALL VALVE PN63

TORQUE VALUES (In Nm without safety coefficient) :

DN	1/4"	3/8"	1/2"	3/4"	1"	1"1/4"	1"1/2"	2"	2"1/2"	3"	4"
TORQUE (Nm)	5	5	5	8	12.5	17	21	30	45	70	100

BOLT TIGHTENING TABLE (in Nm) :

DN	1/4"	3/8"	1/2"	3/4"	1"	1"1/4"	1"1/2"	2"	2"1/2"	3"	4"
TORQUE (Nm)	4	4	8	8	10	13	20	20	35	45	65

STANDARDS :

- Fabrication according to ISO 9001 : 2008
- DIRECTIVE 97/23/CE : CE N° 0035
Risk Category II
- Tests according to EN 12266-1, range A
- Threaded BSP cylindrical ends according to ISO 228-1
- Threaded NPT ends according to ANSI B1.20.1

ADVICE : Our opinion and our advice are not guaranteed and MXT shall not be liable for the consequences of damages. The customer must check the right choice of the products with the real service conditions.

3 PIECES BALL VALVE PN63

INSTALLATION AND MAINTENANCE

BEFORE INSTALLATION :

Pipe-line must be cleaned and free from residual of weldings, rubbish, shaving and every kind of extraneous materials.
Pipe-line must be perfectly aligned and their support properly dimensioned so that there's no external constraint.

Check to use a produce compatible to the services conditions for the sealing of the threaded types.
To tighten the ends, use the appropriate tool.
Use the right bolt tightening so that the ends won't be damaged.

The welding of the ends for the SW and the BW types, must be done with the central part removed.
A gauge can be used to have the good length and alignment between the ends.

INSTALLATION OF THE CENTRAL PART

During the installation of the central part, tighten bolts according to the table below. Tighten bolts in cross.

BOLT TIGHTENING TABLE (in Nm) :

DN	1/4"	3/8"	1/2"	3/4"	1"	1"1/4"	1"1/2"	2"	2"1/2"	3"	4"
TORQUE (Nm)	4	4	8	8	10	13	20	20	35	45	65

CLEANING AND TESTS

Keep closed the valves during the cleaning operation so that there's no impurities between the ball and the body.

Tests under pressure must be done with a cleaned pipe-line.

Open partially the valve for tests. Pressure test do not exceed the valve specifications according to EN 12266-1.

MAINTENANCE

It's recommended to operate the valve twice (open and close) 1 to 2 times per year.

When intervention on the valve, be sure there's no pressure in the pipe-line, there's no fluid in it, and that it is isolated.
The temperature must be low enough to operate without risks.
If there's a corrosive fluid, inert installation before intervention.

When the valve is under pressure :

If there's a leakage between the body and the ends, tighten bolts according to the above table

If there's a leakage at the packing, tighten it slightly so that the leakage disappears.

MAINTENANCE OPERATION IN WORKSHOP

REPLACEMENT OF SEAT GASKETS AND PACKING.

The central part must be removed.

Turn the ball at 45° and removed the seat gaskets.

Operate the valve in closed position to removed the ball. Verify the surface of the ball has no impacts and no scores.

If there are important scores or impacts, replace the ball.

Clean inside the body valve and remove the impurities.

To replace the packing, remove the handle, unscrew the gland nut, extract the stem by the inside of the valve.

Clean the packing seat.

Reassemble thrust washer on stem, introduce stem by the inside of the valve, reassemble packing with packing nut, reassemble hand washer, hand nut and the handle.

Turn stem in closed position and insert the ball.

Then turn the ball in opened position and reassemble the seat.

Place the valve on the installation, tighten bolts according to the above table.

Then proceed to the tests in the same way that the first installation.