

MXT-F7317 Cast Steel 40K Globe Straight Valve  
MXT-F7318 Cast Steel 40K Globe Angel Valve

Accordance to JIS F7400

Flanges as per JIS B2220 - 40K

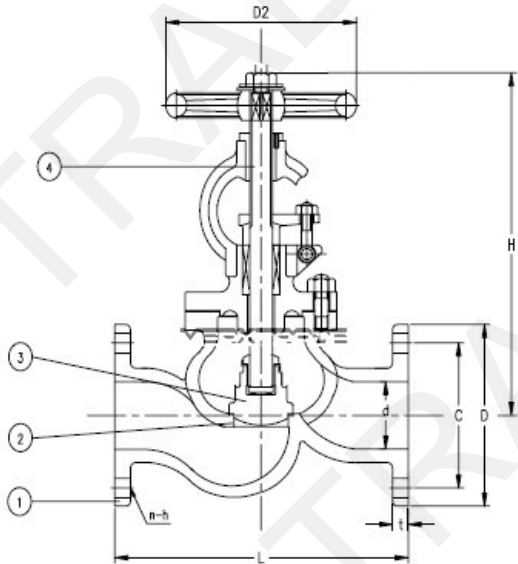

MXT-F7317

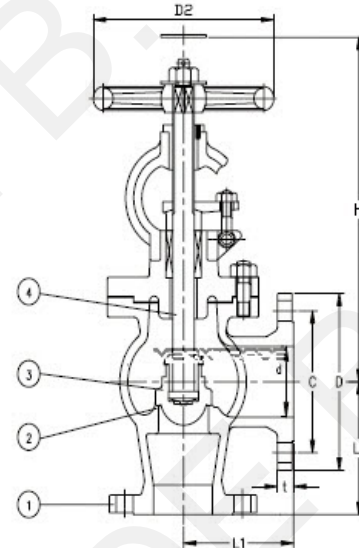

MXT-F7318

No.	Component	Material
1	Body	Cast Steel
2	Seat	Stainless Steel
3	Disc	Stainless Steel
4	Stem	Stainless Steel

	Test Pressure MPa [kgf/cm <sup>2</sup> ]
Body	9.12 [93.0]
Seat	6.69 [68.2]

Size	F7317 - Straight									F7318 - Angle								
	L	D	C	No.	h	t	H	D2	Kg	L1	D	C	No.	h	t	H	D2	Kg
32A	229	140	105	4	19	24	370	200	25.4	114	140	105	4	19	24	350	200	24.9
40A	241	160	120	4	23	24	395	200	30.2	121	160	120	4	23	24	370	200	29.4
50A	292	165	130	8	19	26	435	224	41.0	146	165	130	8	19	26	405	224	40.0
65A	330	200	160	8	23	30	490	250	62.3	165	200	160	8	23	30	455	250	60.3
80A	365	210	170	8	23	32	540	315	79.0	178	210	170	8	23	32	500	315	76.2
100A	432	250	205	8	25	36	640	400	140	216	250	205	8	25	36	590	400	135
125A	508	300	250	8	27	40	720	450	197	254	300	250	8	27	40	660	450	189
150A	559	355	295	12	33	44	815	500	298	279	355	295	12	33	44	740	500	284

Information provided as an indication and subject to possible modification.  
Colours and details can be different than shown in data sheets or pictures.  
Merxtrade BV has no liability for any damages by use off any information,  
displayed on these pages.